

NISSAN
FORKLIFT

by **UNICARRIERS**



**Engine Powered
Forklift Trucks**

Platinum II Series

LPG, Gasoline, Dual Fuel, Diesel

Specification Sheet

3,000 - 7,000 lbs.

Class V | Pneumatic Tire Type



DIMENSIONS

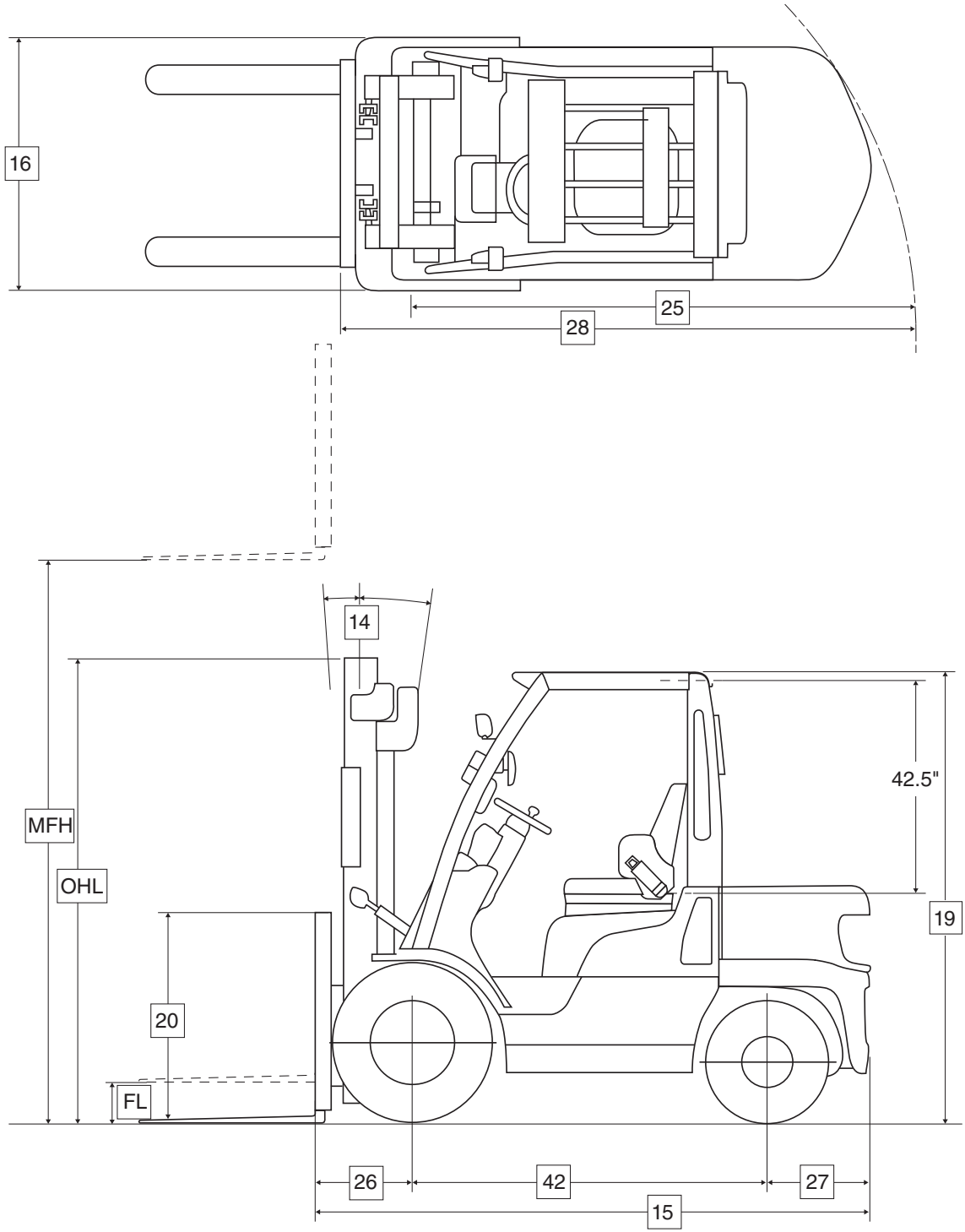

MAIN TRUCK SPECIFICATIONS

CHARACTERISTICS	1	Manufacturer's Name		UniCarriers	UniCarriers	UniCarriers		
	2	Model	Model designation	PF30	PF35	PFS40		
	3		Long Model Code	MP1F1A15JV / LV / DV	MP1F1A18JV / LV / DV	MP1F1A20JV / LV / DV		
CHARACTERISTICS	4	Rated Load Capacity		lb (kg)	3000 (1360)	3500 (1585)	4000 (1815)	
	5	Load Center	Distance	in (mm)	24 (600)	24 (600)	24 (600)	
	6	Power Type			G - LP - G/LP	G - LP - G/LP	G - LP - G/LP	
	7	Operator Orientation			Sit	Sit	Sit	
	DIMENSIONS	8	Tire Type	Front & rear		Pneumatic	Pneumatic	Pneumatic
		9	Wheels	Number (x=driven) front/rear		2 x / 2	2 x / 2	2 x / 2
		10	Mast	Maximum fork height	in (mm)	130 (3300)	130 (3300)	130 (3300)
11			Standard freelif	in (mm)	6.2 (160)	6.2 (160)	6.2 (160)	
12		Forks	Thickness & width	in (mm)	1.5 x 4 (40x100)	1.5 x 4 (40x100)	1.5 x 4 (40x100)	
13			Length	in (mm)	42 (1070)	42 (1070)	42 (1070)	
14		Tilt Angle	Standard mast - fwd/back	degree	6/12	6/12	6/12	
15		Overall Dimensions	Length (to face of forks)	in (mm)	89.0 (2260)	90.2 (2290)	91.3 (2320)	
16			Width (single/dual tires)	in (mm)	41.9 (1065) / 58.3 (1480)	41.9 (1065) / 58.3 (1480)	41.9 (1065) / 58.3 (1480)	
17			Mast lowered (OHL)	in (mm)	84.4 (2145)	84.4 (2145)	84.4 (2145)	
18			Mast extended with LBR	in (mm)	179.3 (4555)	179.3 (4555)	179.3 (4555)	
19			Height - top of OHG	in (mm)	83.3 (2115)	83.3 (2115)	83.3 (2115)	
20			Height - top of standard LBR	in (mm)	48 (1220)	48 (1220)	48 (1220)	
21			Width - standard carriage	in (mm)	36.2 (920)	36.2 (920)	36.2 (920)	
22		Grade Clearance	Ramp breakover angle	tan (%)	49	49	49	
23			Departure angle	tan (%)	39	37	35	
24			Approach angle	tan (%)	37	37	37	
25		Turning Radius	Minimum outside	in (mm)	76.2 (1935)	77.6 (1970)	79.1 (2010)	
26		Overhang	Front	in (mm)	15.7 (400)	15.7 (400)	17.5 (400)	
27			Rear	in (mm)	18.1 (460)	19.3 (490)	20.5 (520)	
28		Min Right Angle Stack	Add load length & clearance	in (mm)	91.9 (2335)	93.3 (2370)	94.9 (2410)	
PERFORMANCE		29	Speeds Maximum	Travel - forward or reverse	mph (kmh)	11.5 (18.5)	11.5 (18.5)	11.5 (18.5)
		30		Lift - full/empty	fpm (mm/sec)	122/127.9 (620/650)	122/127.9 (620/650)	122/127.9 (620/650)
		31		Lowering - full/empty	fpm (mm/sec)	98.4 (500)	98.4 (500)	98.4 (500)
		32	Drawbar Pull Max	Full load	lb (kg)	3705 (1680)	3705 (1680)	3705 (1680)
		33		Empty	lb (kg)	2470 (1120)	2646 (1200)	2932 (1330)
		34	Gradeability Max (1.2 mph)	Full/empty	tan (%)	31 / 28	38 / 24	33 / 21
WEIGHT		35	Truck Weight	Standard truck - no load	lb (kg)	5810 (2635)	6175 (2800)	6505 (2950)
	36	Weight Distribution	Front axle - empty	lb (kg)	2540 (1150)	2440 (1105)	2340 (1060)	
	37		Rear axle - empty	lb (kg)	3270 (1485)	3735 (1695)	4165 (1890)	
	38		Front axle - with rated load	lb (kg)	7710 (3620)	8475 (3985)	9235 (4350)	
	39		Rear axle - with rated load	lb (kg)	1100 (515)	1200 (565)	1270 (600)	
CHASSIS & WHEELS	40	Tire Size	Front - single (or dual) tire	in	6.50-10-10PR	6.50-10-10PR	6.50-10 Solid	
	41		Rear	in	5.00-8-8-PR	5.00-8-8-PR	5.00-8 Solid	
	42	Wheelbase		in (mm)	55.1 (1400)	55.1 (1400)	55.1 (1400)	
	43	Tread - Center of Tire	Front / rear	in (mm)	35/35.4 (890/900)	35/35.4 (890/900)	35/35.4 (890/900)	
	44		Front dual tires	in (mm)	43.1 (1095)	43.1 (1095)	43.1 (1095)	
	45	Headroom	SIP to bottom of OHG	in (mm)	42.5 (1080)	42.5 (1080)	42.5 (1080)	
	46	Counterweight Height		in (mm)	41.9 (1065)	41.9 (1065)	41.9 (1065)	
	47	Step Height		in (mm)	17.7 (450)	17.7 (450)	17.7 (450)	
	48	Ground Clearance	Under mast	in (mm)	4.5 (115)	4.5 (115)	4.5 (115)	
	49		Under power unit	in (mm)	5.3 (135)	5.3 (135)	5.3 (135)	
	50		Under frame (WB center)	in (mm)	5.9 (150)	5.9 (150)	5.9 (150)	
	51	Service Brake	Type		Drum and Shoe	Drum and Shoe	Drum and Shoe	
	52	Parking Brake	Type		Hand	Hand	Hand	
	53	Steering	Type		Full Hydraulic	Full Hydraulic	Full Hydraulic	
DRIVE LINE	54	Engine	Model		K21	K21	K21	
	55	Rated Output	SAE gross	hp (kW) @ rpm	55 (41) @ 2700	55 (41) @ 2700	55 (41) @ 2700	
	56	Rated Torque	SAE gross	ft-lb (Nm) @ rpm	111.4 (151) @ 2000	111.4 (151) @ 2000	111.4 (151) @ 2000	
	57	Displacement		cu in (cm ³)	126 (2065)	126 (2065)	126 (2065)	
	58	Transmission	Type		Automatic	Automatic	Automatic	
	59		Number speeds - fwd/rev		1/1	1/1	1/1	

MAIN TRUCK SPECIFICATIONS

CHARACTERISTICS	1	Manufacturer's Name		UniCarriers	UniCarriers	UniCarriers	UniCarriers	
	2	Model	Model designation	PF40	PFU40	PFD40	PF50	
	3		Long Model Code	MP1F2A20JV / LV / DV	MU1F2A20JV / LV / DV	MY1F2A20V	MP1F2A25JV / LV / DV	
DIMENSIONS	4	Rated Load Capacity	lb (kg)	4000 (1815)	4000 (1815)	4000 (1815)	5000 (2265)	
	5	Load Center	Distance	in (mm)	24 (600)	24 (600)	24 (600)	
	6	Power Type		G - LP - G/LP	G - LP - G/LP	Diesel	G - LP - G/LP	
	7	Operator Orientation		Sit	Sit	Sit	Sit	
	8	Tire Type	Front & rear		Pneumatic	Pneumatic	Pneumatic	Pneumatic
	9	Wheels	Number (x=driven) front/rear		2 x / 2	2 x / 2	2 x / 2	2 x / 2
	10	Mast	Maximum fork height	in (mm)	130 (3300)	130 (3300)	130 (3300)	130 (3300)
	11		Standard freelif	in (mm)	6.1 (155)	6.1 (155)	6.1 (155)	6.1 (155)
	12	Forks	Thickness & width	in (mm)	1.5 x 4 (40x100)	1.5 x 4 (40x100)	1.5 x 4 (40x100)	1.5 x 4 (40x100)
	13		Length	in (mm)	42 (1070)	42 (1070)	42 (1070)	42 (1070)
	14	Tilt Angle	Standard mast - fwd/back	degree	6/12	6/12	6/12	6/12
	15	Overall Dimensions	Length (to face of forks)	in (mm)	96.9 (2460)	96.9 (2460)	96.9 (2460)	99 (2515)
	16		Width (single/dual tires)	in (mm)	45.3 (1150) / 64.6 (1640)	45.3 (1150) / 64.6 (1640)	45.3 (1150) / 64.6 (1640)	45.3 (1150) / 64.6 (1640)
	17		Mast lowered (OHL)	in (mm)	84.4 (2145)	84.4 (2145)	84.4 (2145)	84.4 (2145)
	18		Mast extended with LBR	in (mm)	179.3 (4555)	179.3 (4555)	179.3 (4555)	179.3 (4555)
	19		Height - top of OHG	in (mm)	83.5 (2120)	83.5 (2120)	83.5 (2120)	83.5 (2120)
	20		Height - top of standard LBR	in (mm)	48 (1220)	48 (1220)	48 (1220)	48 (1220)
	21		Width - standard carriage	in (mm)	40.2 (1020)	40.2 (1020)	40.2 (1020)	40.2 (1020)
	22	Grade Clearance	Ramp breakover angle	tan (%)	44	44	44	44
	23		Departure angle	tan (%)	45	45	45	37
	24		Approach angle	tan (%)	32	32	32	32
	25	Turning Radius	Minimum outside	in (mm)	83.5 (2120)	83.5 (2120)	83.5 (2120)	85.8 (2180)
	26	Overhang	Front	in (mm)	17.5 (445)	17.5 (445)	17.5 (445)	17.5 (445)
	27		Rear	in (mm)	16.3 (415)	16.3 (415)	16.3 (415)	18.5 (470)
	28	Min Right Angle Stack	Add load length & clearance	in (mm)	101 (2565)	101 (2565)	101 (2565)	103.3 (2625)
	PERFORMANCE	29	Speeds Maximum	Travel - forward or reverse	mph (kmh)	11.8 (19)	11.8 (19)	11.8 (19)
		30		Lift - full/empty	fpm (mm/sec)	118.1/127.9(600/650)	129.9/137.8 (660/700)	127.9/137.8 (650/700)
		31		Lowering - full/empty	fpm (mm/sec)	98.4 (500)	98.4 (500)	98.4 (500)
32		Drawbar Pull Max	Full load	lb (kg)	3880(1760)	4189 (1900)	4542 (2060)	
33			Empty	lb (kg)	3439 (1560)	3439 (1560)	3616 (1640)	
34		Gradeability Max (1.2 mph)	Full/empty	tan (%)	31 / 28	39 / 28	36 / 28	
WEIGHT	35	Truck Weight	Standard truck - no load	lb (kg)	7145 (3240)	7145 (3240)	7400 (3355)	
	36	Weight Distribution	Front axle - empty	lb (kg)	3365 (1525)	3365 (1525)	3440 (1560)	
	37		Rear axle - empty	lb (kg)	3780 (1715)	3780 (1715)	3960 (1795)	
	38		Front axle - with rated load	lb (kg)	10015 (4709)	10015 (4709)	10095 (4740)	
	39		Rear axle - with rated load	lb (kg)	1130 (531)	1130 (531)	1305 (615)	
CHASSIS & WHEELS	40	Tire Size	Front - single (or dual) tire	in	7.00-12-12PR	7.00-12-12PR	7.00-12-12PR	
	41		Rear	in	6.00-9-10PR	6.00-9-10PR	6.00-9-10PR	
	42	Wheelbase		in (mm)	63 (1600)	63 (1600)	63 (1600)	
	43	Tread - Center of Tire	Front / rear	in (mm)	37.8/38.4 (960/975)	37.8/38.4 (960/975)	37.8/38.4 (960/975)	
	44		Front dual tires	in (mm)	47.4 (1205)	47.4 (1205)	47.4 (1205)	
	45	Headroom	SIP to bottom of OHG	in (mm)	42.5 (1080)	42.5 (1080)	42.5 (1080)	
	46	Counterweight Height		in (mm)	42.1 (1070)	42.1 (1070)	42.1 (1070)	
	47	Step Height		in (mm)	17.9 (455)	17.9 (455)	17.9 (455)	
	48	Ground Clearance	Under mast	in (mm)	4.5 (115)	4.5 (115)	4.5 (115)	
	49		Under power unit	in (mm)	5.3 (135)	5.3 (135)	5.3 (135)	
	50		Under frame (WB center)	in (mm)	6.1 (155)	6.1 (155)	6.1 (155)	
	51	Service Brake	Type		Drum and Shoe	Drum and Shoe	Drum and Shoe	
	52	Parking Brake	Type		Hand	Hand	Hand	
	53	Steering	Type		Full Hydraulic	Full Hydraulic	Full Hydraulic	
DRIVE LINE	54	Engine	Model		K21	K25	QD32	
	55	Rated Output	SAE gross	hp (kW) @ rpm	55 (41) @ 2700	62.9 (46.9) @ 2700	55 (41) @ 2000	
	56	Rated Torque	SAE gross	ft-lb (Nm) @ rpm	111.4 (151) @ 2000	138.7 (188) @ 1600	143.8 (195) @ 1800	
	57	Displacement		cu in (cm ³)	126 (2065)	151.8 (2488)	192.4 (3153)	
	58	Transmission	Type		Automatic	Automatic	Automatic	
59		Number speeds - fwd/rev		1/1	1/1	1/1		

MAIN TRUCK SPECIFICATIONS

1	UniCarriers	UniCarriers	UniCarriers	UniCarriers	UniCarriers	UniCarriers	UniCarriers
2	PFU50	PFD50	PF55	PF60	PFD60	PF70	PFD70
3	MU1F2A25JV / LV / DV	MY1F2A25V	MUJ1F2A28JV / LV / DV	MUG1F2A30JV/LV/DV	MYG1F2A30V	MUG1F2A35JV / LV / DV	MYG1F2A35V
4	5000 (2265)	5000 (2265)	5500 (2495)	6000 (2720)	6000 (2720)	7000 (3175)	7000 (3175)
5	24 (600)	24 (600)	24 (600)	24 (600)	24 (600)	24 (600)	24 (600)
6	G - LP - G/LP	Diesel	G - LP - G/LP	G - LP - G/LP	Diesel	G - LP - G/LP	Diesel
7	Sit	Sit	Sit	Sit	Sit	Sit	Sit
8	Pneumatic	Pneumatic	Pneumatic	Pneumatic	Pneumatic	Pneumatic	Pneumatic
9	2 x / 2	2 x / 2	2 x / 2	2 x / 2	2 x / 2	2 x / 2	2 x / 2
10	130 (3300)	130 (3300)	130 (3300)	130 (3300)	130 (3300)	130 (3300)	130 (3300)
11	6.1 (155)	6.1 (155)	6.1 (155)	6.5 (165)	6.5 (165)	6.5 (164)	6.5 (164)
12	1.5 x 4 (40 x 100)	1.5 x 4 (40 x 100)	1.5 x 4 (40 x 100)	2 x 5 (50 x 125)	2 x 5 (50 x 125)	2 x 5 (50 x 125)	2 x 5 (50 x 125)
13	42 (1070)	42 (1070)	42 (1070)	42 (1070)	42 (1070)	42 (1070)	42 (1070)
14	6/12	6/12	6/12	6/12	6/12	6/12	6/12
15	99 (2515)	99 (2515)	102.8 (2610)	105.5 (2680)	105.5 (2680)	108.5 (2755)	108.5 (2755)
16	45.3 (1150) / 64.6 (1640)	45.3 (1150) / 64.6 (1640)	49.2 (1250) / 65.6 (1665)	49.2 (1250) / 65.6 (1665)	49.2 (1250) / 65.6 (1665)	50.4 (1280) / 67.7 (1720)	50.4 (1280) / 67.7 (1720)
17	84.4 (2145)	84.4 (2145)	85.6 (2175)	85.6 (2175)	85.6 (2175)	91.1 (2315)	91.1 (2315)
18	179.3 (4555)	179.3 (4555)	179.3 (4555)	179.4 (4558)	179.4 (4558)	179.4 (4558)	179.4 (4558)
19	83.5 (2120)	83.5 (2120)	84.6 (2150)	84.6 (2150)	84.6 (2150)	84.8 (2155)	84.8 (2155)
20	48 (1220)	48 (1220)	48 (1220)	48 (1220)	48 (1220)	48 (1220)	48 (1220)
21	40.2 (1020)	40.2 (1020)	40.2 (1020)	40.2 (1020)	40.2 (1020)	40.2 (1020)	40.2 (1020)
22	44	44	52	49	49	51	51
23	37	37	42	43	43	39	39
24	32	32	41	41	41	51	51
25	85.8 (2180)	85.8 (2180)	88.2 (2240)	90.6 (2300)	90.6 (2300)	94.1 (2390)	94.1 (2390)
26	17.5 (445)	17.5 (445)	18.5 (470)	18.9 (480)	18.9 (480)	19.3 (490)	19.3 (490)
27	18.5 (470)	18.5 (470)	20.5 (520)	19.7 (500)	19.7 (500)	22.2 (565)	22.2 (565)
28	103.3 (2625)	103.3 (2625)	106.7 (2710)	109.5 (2780)	109.5 (2780)	113.4 (2880)	113.4 (2880)
29	11.8 (19)	11.8 (19)	11.8 (19)	11.8 (19)	11.5 (18.5)	11.5 (18.5)	11.5 (18.5)
30	129.9/137.8 (660/700)	127.9/137.8 (650/700)	104.3/114.1 (530/580)	104.3/114.1 (530/580)	106.3/114.1 (540/580)	88.6/92.5 (450/470)	86.6/94.5 (440/480)
31	98.4 (500)	98.4 (500)	98.4 (500)	98.4 (500)	98.4 (500)	82.7/70.8 (420/360)	82.7/70.8 (420/360)
32	4189 (1900)	4542 (2060)	4189 (1900)	4189 (1900)	4321 (1960)	4034 (1830)	4056 (1840)
33	3439 (1560)	3858 (1750)	4057 (1840)	4167 (1890)	3858 (1750)	3968 (1800)	3682 (1670)
34	33 / 24	31 / 24	30 / 25	28 / 24	26 / 25	23 / 22	21 / 22
35	7925 (3595)	8180 (3710)	8825 (4000)	9265 (4200)	9520 (4315)	10120 (4590)	10375 (4705)
36	3200 (1450)	3275 (1485)	3395 (1540)	3825 (1735)	3910 (1775)	3760 (1705)	3850 (1745)
37	4725 (2145)	4905 (2225)	5430 (2460)	5440 (2465)	5610 (2540)	6360 (2885)	6525 (2960)
38	11515 (5430)	11595 (5465)	12590 (5935)	13700 (6460)	13795 (6500)	16215 (7240)	16300 (7280)
39	1410 (665)	1585 (745)	1735 (815)	1565 (740)	1725 (815)	1905 (850)	2075 (925)
40	7.00-12-12PR	7.00-12-12PR	28 x 9-15-12PR	28 x 9-15-12PR	28 x 9-15-12PR	250-15-16PR	250-15-16PR
41	6.00-9-10-10PR	6.00-9-10PR	6.50-10-10PR	6.50-10-10PR	6.50-10-10PR	6.50-10-12PR	6.50-10-12PR
42	63 (1600)	63 (1600)	63.8 (1620)	66.9 (1700)	66.9 (1700)	66.9 (1700)	66.9 (1700)
43	37.8/38.4 (960/975)	37.8/38.4 (960/975)	40.6/38.6 (1030/980)	40.6/38.6 (1030/980)	40.6/38.6 (1030/980)	41.7/38.6 (1060/980)	41.7/38.6 (1060/980)
44	47.4 (1205)	47.4 (1205)	47.6 (1210)	47.6 (1210)	47.6 (1210)	48.4 (1230)	48.4 (1230)
45	42.5 (1080)	42.5 (1080)	42.5 (1080)	42.5 (1080)	42.5 (1080)	42.5 (1080)	42.5 (1080)
46	42.1 (1070)	42.1 (1070)	43.3 (1100)	43.3 (1100)	43.3 (1100)	43.5 (1105)	43.5 (1105)
47	17.9 (455)	17.9 (455)	19.1 (485)	19.1 (485)	19.1 (485)	19.3 (490)	19.3 (490)
48	4.5 (115)	4.5 (115)	5.7 (145)	5.7 (145)	5.7 (145)	5.9 (150)	5.9 (150)
49	5.3 (135)	5.3 (135)	6.5 (165)	6.5 (165)	6.5 (165)	6.7 (170)	6.7 (170)
50	6.1 (155)	6.1 (155)	7.3 (185)	7.3 (185)	7.3 (185)	7.5 (190)	7.5 (190)
51	Drum and Shoe	Drum and Shoe	Drum and Shoe	Drum and Shoe	Drum and Shoe	Drum and Shoe	Drum and Shoe
52	Hand	Hand	Hand	Hand	Hand	Hand	Hand
53	Full Hydraulic	Full Hydraulic	Full Hydraulic	Full Hydraulic	Full Hydraulic	Full Hydraulic	Full Hydraulic
54	K25	QD32	K25	K25	QD32	K25	QD32
55	62.9 (46.9) @ 2700	55 (41) @ 2000	62.9 (46.9) @ 2700	62.9 (46.9) @ 2700	55 (41) @ 2000	62.9 (46.9) @ 2700	55 (41) @ 2000
56	138.7 (188) @1600	143.8 (195) @ 1800	138.7 (188) @ 1600	138.7 (188) @1600	143.8 (195) @ 1800	138.7 (188) @ 1600	143.8 (195) @ 1800
57	151.8 (2488)	192.4 (3153)	151.8 (2488)	151.8 (2488)	192.4 (3153)	151.8 (2488)	192.4 (3153)
58	Automatic	Automatic	Automatic	Automatic	Automatic	Automatic	Automatic
59	1/1	1/1	1/1	1/1	1/1	1/1	1/1

MAST SPECIFICATIONS & RATED CAPACITIES

Mast Name		Maximum Fork Height	Overall Height Lowered	Free Lift*	Tilt Angle Forward/Backward	Rated Capacity 24 in (600 mm) Load Center					
						PF30		PF35		PFS40	
						Single Drive	Dual Drive	Single Drive	Dual Drive	Single Drive	Dual Drive
		in (mm)	in (mm)	in (mm)	degrees	lb (kg)		lb (kg)		lb (kg)	
TWO STAGE (Wide view 2W)	2W270	106 (2700)	72.6 (1845)	6.2 (155)	6/12	3000 (1350)	3000 (1350)	3500 (1600)	3500 (1600)	4000 (1800)	4000 (1800)
	2W300	118 (3000)	78.5 (1995)	6.2 (155)	6/12	3000 (1350)	3000 (1350)	3500 (1600)	3500 (1600)	4000 (1800)	4000 (1800)
	2W330	130 (3300)	84.4 (2145)	6.2 (155)	6/12	3000 (1350)	3000 (1350)	3500 (1600)	3500 (1600)	4000 (1800)	4000 (1800)
	2W350	138 (3500)	89.8 (2285)	6.2 (155)	6/12	3000 (1350)	3000 (1350)	3500 (1600)	3500 (1600)	4000 (1800)	4000 (1800)
	2W370	146 (3700)	94.7 (2405)	6.2 (155)	6/12	3000 (1350)	3000 (1350)	3500 (1600)	3500 (1600)	4000 (1800)	4000 (1800)
	2W400	157 (4000)	102.2 (2600)	6.2 (155)	6/6	3000 (1350)	3000 (1350)	3500 (1600)	3500 (1600)	3850 (1750)	3850 (1750)
	2W450	177 (4500)	112.0 (2845)	6.2 (155)	6/6	2900 (1300)	2900 (1300)	3200 (1450)	3200 (1450)	3450 (1550)	3750 (1700)
2W500	197 (5000)	121.9 (3100)	6.2 (155)	6/6	2650 (1200)	2800 (1250)	3100 (1400)	3100 (1400)	3200 (1450)	3300 (1500)	
TWO STAGE (Full free 2F)	2F300	118 (3000)	78.5 (1995)	53.6 (1360)	6/12	3000 (1350)	3000 (1350)	3500 (1600)	3500 (1600)	4000 (1800)	4000 (1800)
	2F330	130 (3300)	84.4 (2145)	59.5 (1510)	6/12	3000 (1350)	3000 (1350)	3500 (1600)	3500 (1600)	4000 (1800)	4000 (1800)
	2F350	138 (3500)	89.8 (2285)	64.8 (1645)	6/12	3000 (1350)	3000 (1350)	3500 (1600)	3500 (1600)	4000 (1800)	4000 (1800)
	2F370	146 (3700)	94.7 (2405)	69.8 (1770)	6/12	3000 (1350)	3000 (1350)	3400 (1550)	3450 (1550)	3900 (1750)	3950 (1800)
	2F400	157 (4000)	102.2 (2600)	77.2 (1960)	6/6	2900 (1300)	2900 (1300)	3300 (1500)	3350 (1500)	3800 (1700)	3850 (1750)
THREE STAGE (Full free 3F)	3F385	152 (3850)	72.6 (1845)	47.0 (1190)	6/6	2900 (1300)	2950 (1350)	3300 (1500)	3350 (1500)	3850 (1750)	3850 (1750)
	3F430	169 (4300)	78.5 (1995)	52.9 (1340)	6/6	2800 (1250)	2850 (1300)	3200 (1450)	3250 (1450)	3550 (1600)	3750 (1700)
	3F475	187 (4750)	84.4 (2145)	58.8 (1490)	6/6	2700 (1200)	2750 (1250)	3100 (1400)	3150 (1450)	3450 (1550)	3450 (1550)
	3F515	203 (5150)	89.8 (2285)	64.1 (1625)	6/6	2600 (1200)	2650 (1200)	2800 (1250)	2950 (1350)	3150 (1450)	3150 (1450)
	3F550	217 (5500)	94.7 (2405)	69.0 (1750)	6/6	2350 (1050)	2550 (1150)	2600 (1200)	2800 (1250)	2700 (1200)	2700 (1200)
	3F600	236 (6000)	102.2 (2600)	76.5 (1940)	6/6	1300 (600)	2150 (950)	1500 (700)	2300 (1050)	1800 (800)	2400 (1100)
	3F650	256 (6500)	112.0 (2845)	86.3 (2190)	6/6	1200 (550)	1500 (700)	1400 (650)	1500 (700)	1700 (750)	1750 (800)
	3F700	276 (7000)	121.9 (3100)	96.2 (2440)	6/6	1100 (500)	1300 (600)	1300 (600)	1400 (650)	1600 (750)	1650 (750)
THREE STAGE OPTVIEW® (3V)	3V360	142 (3600)	72.6 (1845)	48.4 (1225)	6/6	2900 (1300)	2900 (1300)	3300 (1500)	3350 (1500)	3700 (1700)	3700 (1700)
	3V405	159 (4050)	78.5 (1995)	54.3 (1375)	6/6	2800 (1250)	2800 (1250)	3200 (1450)	3250 (1450)	3550 (1600)	3550 (1600)
	3V450	177 (4500)	84.4 (2145)	60.2 (1525)	6/6	2700 (1200)	2700 (1200)	3100 (1400)	3150 (1450)	3450 (1550)	3450 (1550)
	3V490	193 (4900)	89.8 (2285)	65.5 (1660)	6/6	2600 (1200)	2600 (1200)	2800 (1250)	2900 (1300)	3150 (1450)	3150 (1450)
	3V525	207 (5250)	94.7 (2405)	70.4 (1785)	6/6	2350 (1050)	2500 (1150)	2600 (1200)	2700 (1200)	2700 (1200)	2700 (1200)
	3V575	226 (5750)	102.2 (2600)	77.9 (1975)	6/6	1300 (600)	2100 (950)	1500 (700)	1700 (750)	1800 (800)	2000 (900)
	3V633	249 (6330)	112.0 (2845)	87.8 (2230)	6/6	1200 (550)	1300 (600)	1400 (650)	1500 (700)	1700 (750)	1750 (800)

*Without LBR

Mast Name		Maximum Fork Height	Overall Height Lowered	Free Lift*	Tilt Angle Forward/Backward	Rated Capacity 24 in (600 mm) Load Center			
						PF40/PFU40/PFD40			
						Single Drive		Dual Drive	
		in (mm)	in (mm)	in (mm)	degrees	lb (kg)			
TWO STAGE (Wide view 2W)	2W270	106 (2700)	72.6 (1845)	6.1 (150)	6/12	4000 (1800)		4000 (1800)	
	2W300	118 (3000)	78.5 (1995)	6.1 (150)	6/12	4000 (1800)		4000 (1800)	
	2W330	130 (3300)	84.4 (2145)	6.1 (150)	6/12	4000 (1800)		4000 (1800)	
	2W350	138 (3500)	89.8 (2285)	6.1 (150)	6/12	4000 (1800)		4000 (1800)	
	2W370	146 (3700)	94.7 (2405)	6.1 (150)	6/12	4000 (1800)		4000 (1800)	
	2W400	157 (4000)	102.2 (2600)	6.1 (150)	6/6	4000 (1800)		4000 (1800)	
	2W450	177 (4500)	112.0 (2845)	6.1 (150)	6/6	3850 (1750)		3850 (1750)	
2W500	197 (5000)	121.9 (3100)	6.1 (150)	6/6	3450 (1550)		3700 (1700)		
TWO STAGE (Full free 2F)	2F300	118 (3000)	78.5 (1995)	53.5 (1355)	6/12	4000 (1800)		4000 (1800)	
	2F330	130 (3300)	84.4 (2145)	59.4 (1505)	6/12	4000 (1800)		4000 (1800)	
	2F350	138 (3500)	89.8 (2285)	64.7 (1640)	6/12	4000 (1800)		4000 (1800)	
	2F370	146 (3700)	94.7 (2405)	69.6 (1765)	6/12	4000 (1800)		4000 (1800)	
	2F400	157 (4000)	102.2 (2600)	77.1 (1955)	6/6	3950 (1800)		4000 (1800)	
THREE STAGE (Full free 3F)	3F385	152 (3850)	72.6 (1845)	47.2 (1195)	6/6	4000 (1800)		4000 (1800)	
	3F430	169 (4300)	78.5 (1995)	53.1 (1345)	6/6	3850 (1750)		3900 (1750)	
	3F475	187 (4750)	84.4 (2145)	59.0 (1495)	6/6	3700 (1700)		3750 (1700)	
	3F515	203 (5150)	89.8 (2285)	64.3 (1630)	6/6	3300 (1500)		3650 (1650)	
	3F550	217 (5500)	94.7 (2405)	69.2 (1755)	6/6	2950 (1350)		3550 (1600)	
	3F600	236 (6000)	102.2 (2600)	76.7 (1945)	6/6	1900 (850)		3400 (1550)	
	3F650	256 (6500)	112.0 (2845)	86.5 (2195)	6/6	1800 (800)		3250 (1450)	
3F700	276 (7000)	121.9 (3100)	96.4 (2445)	6/6	700 (300)		2400 (1100)		
THREE STAGE OPTVIEW® (3V)	3V360	142 (3600)	72.8 (1850)	47.2 (1195)	6/6	3900 (1750)		3900 (1750)	
	3V405	159 (4050)	78.7 (2000)	53.1 (1345)	6/6	3700 (1700)		3750 (1700)	
	3V450	177 (4500)	84.6 (2150)	59.0 (1495)	6/6	3600 (1650)		3650 (1650)	
	3V490	193 (4900)	90.0 (2290)	64.3 (1630)	6/6	3300 (1500)		3400 (1550)	
	3V525	207 (5250)	94.9 (2415)	69.2 (1755)	6/6	3000 (1350)		3200 (1450)	
	3V575	226 (5750)	102.4 (2605)	76.7 (1945)	6/6	2500 (1150)		2900 (1300)	
	3V633	249 (6330)	112.2 (2850)	86.5 (2195)	6/6	2300 (1050)		2500 (1150)	
3V688	271 (6880)	122.0 (3100)	96.4 (2445)	6/6	1900 (850)		2200 (1000)		

*Without LBR

MAST SPECIFICATIONS & RATED CAPACITIES

Mast Name		Maximum Fork Height	Overall Height Lowered	Free Lift*	Tilt Angle Forward/Backward	Rated Capacity 24 in (600 mm) Load Center	
						PF50/PFU50/PFD50	
						Single Drive	Dual Drive
		in (mm)	in (mm)	in (mm)	degrees	lb (kg)	
TWO STAGE (Wide view 2W)	2W270	106 (2700)	72.6 (1845)	6.1 (150)	6/12	5000 (2250)	5000 (2250)
	2W300	118 (3000)	78.5 (1995)	6.1 (150)	6/12	5000 (2250)	5000 (2250)
	2W330	130 (3300)	84.4 (2145)	6.1 (150)	6/12	5000 (2250)	5000 (2250)
	2W350	138 (3500)	89.8 (2285)	6.1 (150)	6/12	5000 (2250)	5000 (2250)
	2W370	146 (3700)	94.7 (2405)	6.1 (150)	6/12	5000 (2250)	5000 (2250)
	2W400	157 (4000)	102.2 (2600)	6.1 (150)	6/6	5000 (2250)	5000 (2250)
	2W450	177 (4500)	112.0 (2845)	6.1 (150)	6/6	4400 (2000)	4850 (2200)
	2W500	197 (5000)	121.9 (3100)	6.1 (150)	6/6	3700 (1700)	4650 (2100)
TWO STAGE (Full free 2F)	2F300	118 (3000)	78.5 (1995)	53.5 (1355)	6/12	5000 (2250)	5000 (2250)
	2F330	130 (3300)	84.4 (2145)	59.4 (1505)	6/12	5000 (2250)	5000 (2250)
	2F350	138 (3500)	89.8 (2285)	64.7 (1640)	6/12	5000 (2250)	5000 (2250)
	2F370	146 (3700)	94.7 (2405)	69.6 (1765)	6/12	5000 (2250)	5000 (2250)
	2F400	157 (4000)	102.2 (2600)	77.1 (1955)	6/6	4950 (2250)	5000 (2250)
THREE STAGE (Full free 3F)	3F385	152 (3850)	72.6 (1845)	47.2 (1195)	6/6	5000 (2250)	5000 (2250)
	3F430	169 (4300)	78.5 (1995)	53.1 (1345)	6/6	4700 (2150)	4900 (2200)
	3F475	187 (4750)	84.4 (2145)	59.0 (1495)	6/6	4300 (1950)	4750 (2150)
	3F515	203 (5150)	89.8 (2285)	64.3 (1630)	6/6	3650 (1650)	4600 (2100)
	3F550	217 (5500)	94.7 (2405)	69.2 (1755)	6/6	3350 (1500)	4450 (2000)
	3F600	236 (6000)	102.2 (2600)	76.7 (1945)	6/6	2100 (950)	4300 (1950)
	3F650	256 (6500)	112.0 (2845)	86.5 (2195)	6/6	2000 (900)	3850 (1750)
	3F700	276 (7000)	121.9 (3100)	96.4 (2445)	6/6	1500 (700)	2600 (1200)
THREE STAGE 4 CYLINDER (3V)	3V360	142 (3600)	72.8 (1850)	47.2 (1195)	6/6	4900 (2200)	4900 (2200)
	3V405	159 (4050)	78.7 (2000)	53.1 (1345)	6/6	4700 (2150)	4700 (2150)
	3V450	177 (4500)	84.6 (2145)	59.0 (1495)	6/6	4300 (1950)	4500 (2050)
	3V490	193 (4900)	90.0 (2290)	64.3 (1630)	6/6	3900 (1750)	4300 (1950)
	3V525	207 (5250)	94.9 (2415)	69.2 (1755)	6/6	3500 (1600)	4000 (1800)
	3V575	226 (5750)	102.4 (2605)	76.7 (1945)	6/6	3000 (1350)	3900 (1750)
	3V633	249 (6330)	112.2 (2850)	86.5 (2195)	6/6	2600 (1200)	3500 (1600)
	3V688	271 (6880)	122.0 (3100)	96.4 (2445)	6/6	2300 (1050)	2500 (1150)

*Without LBR

Mast Name		Maximum Fork Height	Overall Height Lowered	Free Lift*	Tilt Angle Forward/Backward	Rated Capacity 24 in (600 mm) Load Center	
						PF55	
						Single Drive	Dual Drive
		in (mm)	in (mm)	in (mm)	degrees	lb (kg)	
TWO STAGE (Wide view 2W)	2W270	106 (2700)	73.8 (1875)	6.1 (150)	6/12	5500 (2500)	5500 (2500)
	2W300	118 (3000)	79.7 (2025)	6.1 (150)	6/12	5500 (2500)	5500 (2500)
	2W330	130 (3300)	85.6 (2175)	6.1 (150)	6/12	5500 (2500)	5500 (2500)
	2W350	138 (3500)	90.9 (2310)	6.1 (150)	6/12	5500 (2500)	5500 (2500)
	2W370	146 (3700)	95.9 (2440)	6.1 (150)	6/12	5500 (2500)	5500 (2500)
	2W400	157 (4000)	103.3 (2625)	6.1 (150)	6/6	5500 (2500)	5500 (2500)
	2W450	177 (4500)	113.2 (2880)	6.1 (150)	6/6	5300 (2400)	5300 (2400)
	2W500	197 (5000)	123.0 (3125)	6.1 (150)	6/6	4300 (1950)	5200 (2350)
TWO STAGE (Full free 2F)	2F300	118 (3000)	79.7 (2025)	53.8 (1365)	6/12	5500 (2500)	5500 (2500)
	2F330	130 (3300)	85.6 (2175)	59.7 (1515)	6/12	5500 (2500)	5500 (2500)
	2F350	138 (3500)	90.9 (2310)	65.1 (1650)	6/12	5500 (2500)	5500 (2500)
	2F370	146 (3700)	95.9 (2440)	70.0 (1775)	6/12	5500 (2500)	5500 (2500)
	2F400	157 (4000)	103.3 (2625)	77.5 (1965)	6/6	5500 (2500)	5500 (2500)
THREE STAGE (Full free 3F)	3F385	152 (3850)	79.7 (2025)	55.7 (1410)	6/6	5500 (2500)	5500 (2500)
	3F430	169 (4300)	85.6 (2175)	61.6 (1560)	6/6	5300 (2400)	5300 (2400)
	3F475	187 (4750)	90.9 (2310)	66.9 (1695)	6/6	5100 (2300)	5100 (2300)
	3F515	203 (5150)	95.9 (2440)	71.8 (1820)	6/6	4000 (1800)	4900 (2200)
	3F550	217 (5500)	103.3 (2625)	79.3 (2010)	6/6	3200 (1450)	4800 (2200)
	3F600	236 (6000)	113.2 (2880)	89.1 (2260)	6/6	2300 (1050)	4600 (2100)
	3F650	256 (6500)	123.0 (3125)	99.0 (2510)	6/6	1100 (500)	4100 (1850)
	3F700	276 (7000)	132.9 (3380)	108.8 (2760)	6/6	550 (250)	3000 (1350)
THREE STAGE OPTVIEW® (3V)	3V385	152 (3850)	79.7 (2025)	55.7 (1410)	6/6	5450 (2450)	5450 (2450)
	3V430	169 (4300)	85.6 (2175)	61.6 (1560)	6/6	5300 (2400)	5300 (2400)
	3V470	185 (4700)	90.9 (2310)	66.9 (1695)	6/6	5000 (2250)	5000 (2250)
	3V505	199 (5050)	95.9 (2440)	71.8 (1820)	6/6	3750 (1700)	4900 (2200)
	3V555	219 (5550)	103.3 (2625)	79.3 (2010)	6/6	2800 (1250)	4700 (2150)
	3V600	236 (6000)	113.2 (2880)	89.1 (2260)	6/6	1850 (850)	4500 (2050)
	3V650	256 (6500)	123.0 (3125)	99.0 (2510)	6/6	1200 (550)	4000 (1800)
	3V700	276 (7000)	132.9 (3380)	108.8 (2760)	6/6	650 (300)	3400 (1550)

*Without LBR

MAST SPECIFICATIONS & RATED CAPACITIES

Mast Name		Maximum Fork Height	Overall Height Lowered	Free Lift*	Tilt Angle Forward/Backward	Rated Capacity 24 in (600 mm) Load Center	
						PF60/PFD60	
						Single Drive	Dual Drive
		in (mm)	in (mm)	in (mm)	degrees	lb (kg)	
TWO STAGE (Wide view 2W)	2W270	106 (2700)	73.8 (1875)	6.5 (165)	6/12	6000 (2700)	6000 (2700)
	2W300	118 (3000)	79.7 (2028)	6.5 (165)	6/12	6000 (2700)	6000 (2700)
	2W330	130 (3300)	85.6 (2175)	6.5 (165)	6/12	6000 (2700)	6000 (2700)
	2W350	138 (3500)	90.9 (2310)	6.5 (165)	6/12	6000 (2700)	6000 (2700)
	2W370	146 (3700)	95.9 (2440)	6.5 (165)	6/12	6000 (2700)	6000 (2700)
	2W400	157 (4000)	103.3 (2625)	6.5 (165)	6/6	6000 (2700)	6000 (2700)
	2W450	177 (4500)	113.2 (2880)	6.5 (165)	6/6	5600 (2550)	5900 (2700)
	2W500	197 (5000)	123.0 (3125)	6.5 (165)	6/6	5150 (2300)	5700 (2600)
TWO STAGE (Full free 2F)	2F300	118 (3000)	79.7 (2025)	53.4 (1355)	6/12	6000 (2700)	6000 (2700)
	2F330	130 (3300)	85.6 (2175)	59.3 (1505)	6/12	6000 (2700)	6000 (2700)
	2F350	138 (3500)	90.9 (2310)	64.6 (1635)	6/12	6000 (2700)	6000 (2700)
	2F370	146 (3700)	95.9 (2440)	70.0 (1775)	6/12	6000 (2700)	6000 (2700)
	2F400	157 (4000)	103.3 (2625)	77.0 (1955)	6/6	5950 (2700)	6000 (2700)
THREE STAGE (Full free 3F)	3F385	152 (3850)	79.7 (2028)	54.8 (1390)	6/6	6000 (2700)	6000 (2700)
	3F430	169 (4300)	85.6 (2175)	60.7 (1540)	6/6	5800 (2650)	5800 (2650)
	3F475	187 (4750)	90.9 (2310)	66.0 (1675)	6/6	5600 (2550)	5650 (2550)
	3F515	203 (5150)	95.9 (2440)	70.9 (1800)	6/6	4700 (2150)	5450 (2450)
	3F550	217 (5500)	103.3 (2625)	78.4 (1990)	6/6	3700 (1700)	5300 (2400)
	3F600	236 (6000)	113.2 (2880)	88.2 (2240)	6/6	2650 (1200)	5100 (2300)
	3F650	256 (6500)	123.0 (3125)	98.1 (2490)	6/6	1500 (700)	4550 (2050)
	3F700	276 (7000)	132.9 (3380)	107.9 (2740)	6/6	1000 (450)	3000 (1350)
THREE STAGE OPTVIEW® (3V)	3V385	152 (3850)	79.7 (2028)	54.8 (1390)	6/6	5950 (2700)	5950 (2700)
	3V430	169 (4300)	85.6 (2175)	60.7 (1540)	6/6	5750 (2650)	5750 (2650)
	3V470	185 (4700)	90.9 (2310)	66.0 (1675)	6/6	5500 (2500)	5550 (2500)
	3V505	199 (5050)	95.9 (2440)	70.9 (1800)	6/6	4700 (2150)	5450 (2450)
	3V555	219 (5550)	103.3 (2625)	78.4 (1990)	6/6	3700 (1700)	5300 (2400)
	3V600	236 (6000)	113.2 (2880)	88.2 (2240)	6/6	2600 (1200)	5000 (2250)
	3V650	256 (6500)	123.0 (3125)	98.1 (2490)	6/6	1400 (650)	4500 (2050)
	3V700	276 (7000)	132.9 (3380)	107.9 (2740)	6/6	1000 (450)	3000 (1350)

*Without LBR

Mast Name		Maximum Fork Height	Overall Height Lowered	Free Lift*	Tilt Angle Forward/Backward	Rated Capacity 24 in (600 mm) Load Center	
						PF70/PFD70	
						Single Drive	Dual Drive
		in (mm)	in (mm)	in (mm)	degrees	lb (kg)	
TWO STAGE (Wide view 2W)	2W300	118 (3000)	85.8 (2180)	6.5 (165)	6/12	7000 (3150)	7000 (3150)
	2W330	130 (3300)	91.1 (2315)	6.5 (165)	6/12	7000 (3150)	7000 (3150)
	2W350	138 (3500)	96.1 (2445)	6.5 (165)	6/12	7000 (3150)	7000 (3150)
	2W370	146 (3700)	103.5 (2630)	6.5 (165)	6/12	7000 (3150)	7000 (3150)
	2W400	157 (4000)	113.4 (2885)	6.5 (165)	6/6	6900 (3100)	7000 (3150)
	2W450	177 (4500)	123.2 (3130)	6.5 (165)	6/6	6800 (3050)	6900 (3100)
	2W500	197 (5000)	133.1 (3385)	6.5 (165)	6/6	6600 (2950)	6700 (3000)
TWO STAGE (Full free 2F)	2F300	118 (3000)	85.8 (2180)	57 (1445)	6/12	7000 (3150)	7000 (3150)
	2F330	130 (3300)	91.1 (2315)	62 (1570)	6/12	7000 (3150)	7000 (3150)
	2F350	138 (3500)	96.1 (2445)	67 (1700)	6/12	7000 (3150)	7000 (3150)
	2F370	146 (3700)	103.5 (2630)	74 (1875)	6/12	7000 (3150)	7000 (3150)
	2F400	157 (4000)	113.4 (2885)	84 (2130)	6/6	6900 (3100)	7000 (3150)
THREE STAGE (Full free 3F)	3F355	140 (3550)	74.2 (1885)	43.5 (1100)	6/6	7000 (3150)	7000 (3150)
	3F400	157 (4000)	80.1 (2035)	49.4 (1250)	6/6	7000 (3150)	7000 (3150)
	3F445	175 (4450)	86.0 (2185)	55.4 (1405)	6/6	6800 (3050)	6800 (3050)
	3F485	191 (4850)	91.3 (2320)	60.7 (1540)	6/6	6600 (2950)	6600 (2950)
	3F520	205 (5200)	96.3 (2450)	65.6 (1665)	6/6	6300 (2800)	6400 (2850)
	3F570	224 (5700)	103.7 (2635)	73.1 (1855)	6/6	5300 (2400)	6000 (2700)
	3F620	244 (6200)	113.6 (2890)	82.9 (2105)	6/6	3500 (1600)	4000 (1800)
	3F670	264 (6700)	123.4 (3135)	92.8 (2355)	6/6	2500 (1150)	3000 (1350)
THREE STAGE OPTVIEW® (3V)	3V385	152 (3850)	80.1 (2035)	49.4 (1250)	6/6	7000 (3150)	7000 (3150)
	3V430	169 (4300)	86.0 (2185)	55.4 (1405)	6/6	6900 (3100)	6900 (3100)
	3V470	185 (4700)	91.3 (2320)	60.7 (1540)	6/6	6700 (3000)	6700 (3000)
	3V505	199 (5050)	96.3 (2450)	65.6 (1665)	6/6	6500 (2900)	6500 (2900)
	3V555	219 (5550)	103.7 (2635)	73.1 (1855)	6/6	6200 (2800)	6300 (2800)
	3V600	236 (6000)	113.6 (2890)	82.9 (2105)	6/6	4400 (2000)	5000 (2250)
	3V650	256 (6500)	123.4 (3135)	92.8 (2355)	6/6	3200 (1450)	4500 (2050)
	3V700	276 (7000)	133.3 (3390)	102.6 (2605)	6/6	3000 (1350)	4000 (1800)

*Without LBR

STANDARD EQUIPMENT

- K21 and K25 electronic fuel injected Industrial Engines
- 3-Way Catalytic Converter (Gas/LP)
- 2-Stage Engine and Transmission Protection System (Gas/LP)
- QD32 Diesel Engine
- Single lift/tilt hydraulic control lever
- Seat-actuated Operator Presence System:
 - Auto-mast lock
 - Return-to-Neutral
 - Parking brake with warning buzzer
- Horn & back-up alarm
- Full suspension seat with weight & lumbar adjustment
- Overhead guard mounted LED headlights
- Adjustable tilt steering wheel with memory
- High visibility carriage (up to 5500-lbs capacity)
- Multi-function LCD:
 - Hour meter, Clock, Calendar
 - Operator PIN security access
 - On-board diagnostics
 - Programmable service reminders
 - Engine coolant temperature gauge
 - Speedometer and F/N/R transmission indicator
 - Low fuel warning light (LP, Dual Fuel)
 - Fuel gauge (Gas, Diesel)
- Maximum travel speed control
- 3-Spool control valve with pressure relief
- 5-piece reinforced overhead guard
- Swing-out LPG tank bracket
- Cushioned stability control

OPTIONAL EQUIPMENT

- Power/Economy controlled acceleration mode ^{2,3}
- High/Low travel speed control ^{2,3}
- Rearview mirrors (glass or impact resistant)
- Rear LED combination light package (stop, turn, back-up)
- Reverse-activated LED drive light
- Strobe & rotating beacons
- Electronic fingertip hydraulic controls¹ (deck mounted)
- Integral or hang-on sideshifter
- Tilt cylinder boots & covers
- Dual drive tires
- Bottler's tilt
- Polycarbonate overhead guard cover
- Swing-down LP tank bracket ³
- Self-adjusting backup alarm
- Rear right pillar assist grip with horn button¹
- Engine block heater
- Open core radiator
- Air intake pre-cleaner
- Radiator screen
- U.L. safety rating
- Fire Extinguisher
- Steering wheel spinner knob

¹ Not available on all models. Consult Factory.

² Features can be combined. Available with rocker or key switch. Select Economy setting "always on" for greatest fuel savings.

³ Not available on diesel model.

Ergonomics & Comfort

The Platinum II Series offers a variety of operator conveniences for greater productivity including standard full suspension seat for enhanced shock absorption. Seat includes lumbar support adjustment, weight-adjustment plus operator restraint armrests. Non-cinching seat belt provides greater range of movement. Adjustable tilt steering column with memory lever. Operator Presence System with Return-to-Neutral and Auto-Mast Lock (automatically locking mast lift and tilt when the operator leaves the seat). Audible and visual warnings notify operator if seat belt is not engaged while traveling, or if parking brake is not applied before exiting truck. Floating powertrain includes four independent dampers, to reduce vibrations that can cause operator fatigue.

Compact front cowl offers generous leg and foot room. Low profile design provides ample head clearance. Optional secure assist grip is mounted to the rear, right pillar, keeping the operator's hand safely inside the compartment during reverse travel. Can be purchased with an optional swivel seat that pivots 15° to left and right. [Reduces headroom by 1" (25mm)]. Hydrostatic power steering system reduces operator effort for easier maneuvering and less fatigue. Automotive-style levers simplify repetitive actions for greater operator focus. Exclusive single hydraulic control lever design combines lift and tilt operations into one fluid motion for greater productivity. Separate control levers available at no charge. Optional auto-tilt leveling system assists operator during mast/fork positioning. Optional fingertip control levers with adjustable armrest provide enhanced comfort.

Efficiency & Control

Welded metal assist grip combined with replaceable metal traction plate bolted to a wide, low entry step, provide secure footing and grip for this often-repeated task. Small steering wheel delivers control and provides operator with clear view of meter panel with visibility to warnings and indicators.

Control of maximum travel speed is adjustable through the meter panel by a trained service technician. Optional Power/Economy controlled acceleration mode adjusts throttle sensitivity to increase fuel efficiency, extend drivetrain life and reduce excessive tire wear. An optional LP tank holder swings out 90°, then pulls down to a manageable height, requiring less force for simplified change out.

Exclusive maintenance-free cushioned stability control with rubber dampers located between rear axle and body enhance lateral stability under normal driving conditions.

Legendary K-Series Industrial Engines

Platinum II LP/Gas models are powered by our K21 (2.1 ℓ) and K25 (2.5 ℓ) electronically controlled fuel injected industrial engines which include a bottom-bypass design thermostat, to eliminate hot spots during start up and prolong engine life. Designed and tested specifically for industrial applications, K21 and K25 engines deliver power and torque (in the low rpm range) more efficiently. An engine protection and warning system is standard, reducing speed in case of excessive heat generation or oil pressure loss. System includes three main components [Engine Control Module (ECM), Vehicle Control Module (VCM), and Multi-function LCD System]. The ECM analyzes engine performance parameters and optimizes engine operation for enhanced productivity and lower fuel consumption. The ECM responds to sensor input by controlling basic engine-related functions (proper air/fuel ratio, torque and speed) based on application requirements. The VCM monitors sensors for changing conditions, alerting operator through warning indicators located on the meter panel. Communication among these components occurs through a Controller Area Network (CAN) system.

QD32 Diesel Engine

The QD32 diesel engine delivers high performance with low emission levels. Platinum II models powered by the QD32 include the same Vehicle Control Module (VCM) which monitors sensors for changing conditions, and alerts the operator through indicators appearing on the meter panel. Additionally, the QD32 incorporates a Quick Glow System for reduced glow times, delivering reliable engine start up in cold weather.

Low Emissions

UCA's global commitment to preserving and protecting the environment is evident in our low emission engines. K21/K25 engines include a three-way catalytic muffler and an automotive-type, closed-loop design, providing cleaner exhaust emissions through lower CO (Carbon Monoxide) and combined HC+NOx (Greenhouse Gases) levels. Operators will experience low noise levels during idle and while driving at maximum travel speeds.

Lower Operating Costs

No tools are required to remove the one-piece diamond tread floorboard, promoting fast, simple access to hydraulic components, and other serviceable components. Detachable side panels and a wide-open hood provide a roomy area for service technicians. Unique five-piece reinforced overhead guard simplifies replacement of individual components if necessary, saving time and money. An opening in the dash panel allows for fast brake fluid level checks. Multi-function LCD panel with on-board diagnostics help reduce service time. Service reminder settings keep periodic/planned maintenance on schedule.



SS-Plat II Pn 09-2014

Printed in U.S.A.

Platinum II and OptiView are registered trademarks of UniCarriers Americas Corporation. UniCarriers Americas Corporation reserves the right to make product changes relating to colors, equipment, specification or available options without notice.

For more information, contact your Nissan Forklift by UniCarriers dealer representative.

