

BARRETT

by **UNICARRIERS**

SCXB Series

Stand Up Counterbalanced Trucks
Battery Powered Models



3,000 lbs. Capacity
3,500 lbs. Capacity
4,000 lbs. Capacity



BARRETT

by **UNICARRIERS**[®]

Two years. Unlimited hours. It's more than just the best standard limited warranty in the business*. It's also a reflection on the engineering and workmanship that go into our forklifts — and the result of more than half a century of bringing innovation and excellence to forklift manufacturing.



Up Your UpTime

Reliability is key and that is no mistake. Design, engineering and relentless testing are part of our DNA. The result is what we expect and what you demand.



Comfort Zone

Work comes first, but there are amenities that make the experience more pleasurable. And happy drivers are statistically more productive.



Power & Performance

Our 100% AC motors and controller system and intuitive designs allow you to move in a way that makes sense. The resulting productivity saves you time, money and driver mishaps.



Sweet Savings

Our low cost of ownership is something you can take to the bank. We take our commitment to delivering value seriously because we know you do.

Up and down narrow warehouse aisles, in and out of trailers — the SCXB Series combines extraordinary maneuverability with exceptional performance in a truck that's both powerful and reliable. Specifically designed for applications that require operators to frequently get on and off of the truck, the SCXB is loaded with ergonomic features like the lowest entry step in the industry and an inclined floorboard to reduce operator fatigue and maximize productivity.

SCXB Series forklifts are designed and engineered with performance features only available from UniCarriers. As you look through these pages, check for the symbols below — each represents a feature only available from the Barrett brand or that provides a proven performance advantage far above any you will find on competitive equipment.



Used in a wide variety of applications, including freezers, coolers, pallet transfer and dock operations, the SCXB Series brings greater performance and value to:

- Food products companies
- Warehousing operations
- Light manufacturing
- Trucking operations

...or any business that wants to emphasize its commitment to both green initiatives and optimum productivity.



Play It Safe

Your employees' well-being is an imperative. Standard protection features mean greater confidence in the workplace.



Control Freak

Our advanced features give you control to promote operator security, manage your productivity, contain costs, or do all these things at once.



Make It Yours

Choose from a variety of options to customize your ride. If you don't see what you need, contact your authorized Barrett by UniCarriers dealer for help.



To learn more, and find a dealer near you, visit UniCarriersAmericas.com



Up Your UpTime

SCXB Series stand-up trucks have been specifically designed to use fewer parts, require less scheduled maintenance, provide extended battery life and deliver more consistent power and performance.



Fewer Motors To Maintain

The SCXB uses a single motor to power both steering and hydraulics — reducing the number of parts and energy consumption.

BARRETT

by **UNICARRIERS**



Simply Reliable

Our brushless 100% AC drive motor and hydraulics systems deliver ultra-reliable performance, fewer serviceable parts and lower operating costs.

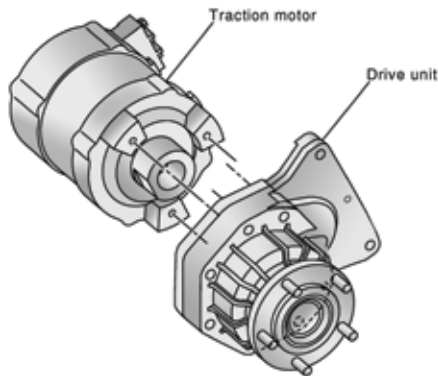

Dependable Drive Units

Dependable performance is achieved through the synching of our AC induction motors with a simple, yet effective, transmission design. The result is less complexity, fewer parts and reduced maintenance.



Stay Cool

At higher operating temperatures, **built-in thermal sensors** will alert the operator and automatically reduce performance to protect the drive motors, pump motor and controller system.



Simple Efficiency

The use of Hall Effect sensors and encoders — plus magnetic reed switches and inductive proximity switches — means **no extra wiring of heaters is needed...**and reduces the effect of dirt and debris on the truck's operation.



Get Back Up Again Quickly

Our sophisticated CAN-Bus Network continuously monitors operating systems providing smooth operation and continuous diagnostics of all truck components.

The LCD meter panel is your portal to truck performance, providing access to systems' status, fault codes, service history, and driver alerts to minimize maintenance and downtime. Unlike competitive models, **no tablet, laptop or handset tool is needed.**



Comfort Zone

Take a look at the features we offer, the materials we use and the thought that went into the SCXB Series, and you'll see that we've addressed every aspect of operator comfort in designing this highly efficient truck.

Plush Surroundings

The operator compartment features a padded armrest, an extra tall 57" backrest, super thick floor mat and optional kneepad.



A Smooth Ride

Unlike most competitive forklifts, the platform of the SCXB is not bolted to the frame, but sits on **vibration isolators** to absorb shocks.



57" Backrest

Padded Armrest

Vibration Isolators

Cushioned Floor Mat

BARRETT

by **UNICARRIERS**



Perfect Vision

The overhead guard is designed with wide canopy channels and an angled crossbar to produce clearer visibility at higher lift heights.



Driver-Friendly Environment

Designed for the operator to lean back comfortably, the floor is angled for optimum foot position, and two large cut-outs accommodate bigger boot sizes. The truck is designed for side stance operation and maximum driver comfort while traveling in either forward or reverse.



Ergo Design

Shaped with an angled grip for comfortable all-day operation, our joystick is ergonomically designed for comfort and ease-of-use — even with freezer gloves. The low-effort, sealed switches help reduce operator fatigue.



Easy Entry

The SCXB has the **shortest step height in the industry** at just 8.4" — and along with a wide compartment entry, it is the ideal design for operators who are constantly getting on and off the truck throughout their shifts.



Power & Performance



Smooth Moves

SCXB trucks feature a compact wheelbase and two individually controlled AC motors so it can turn within its own footprint for unsurpassed maneuverability.

With quick acceleration, fast travel and lift speeds, plus excellent maneuverability and precise control, the SCXB Series delivers optimal performance and productivity in a wide range of applications and environments.

Highly Tuned Performance

Specifically designed for the SCXB, the AC motors are matched with a controller that's tuned to their precise torque and power curves. The result is quick acceleration, higher productivity, low energy consumption and industry-leading travel and lift speeds.



Travel Speeds

7.8/8
MPH

Full load / No load

Lift Speeds

71/114
FPM

Full load / No load

Gradeability

29.1%

Loaded

SCXB forklifts deliver exceptional power and performance producing faster cycle times and more productive operations.

*Specifications based on 3000 lb capacity model

Customized Productivity

Three factory programmed performance settings allow you to program the right balance of power and economy for your operation.

- E Economy Mode**
Extended operating hours achieved with only slightly reduced performance.
- P Performance Mode**
Offers mid-range settings for normal performance needs.
- H High-Performance Mode**
To reach maximum desired performance.

Additionally, through the Manual Mode, you can customize and fine-tune settings to your precise needs and specifications.

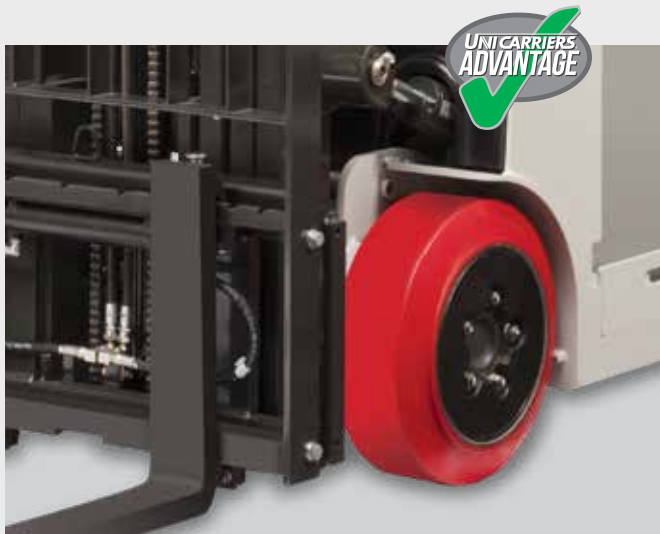
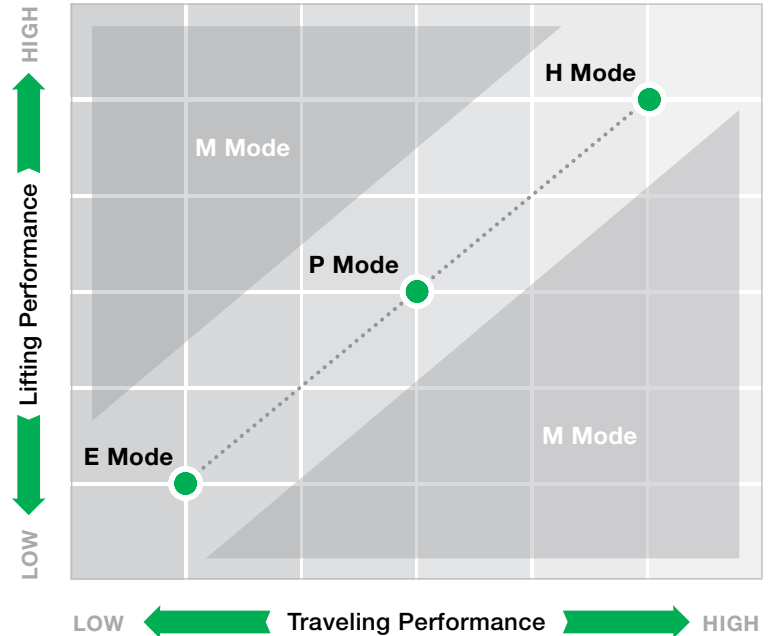

Driving Productivity

Large **18" drive tires** provide long wear, exceptional traction and a smooth ride over dock plates, uneven floors and floor joints.



Easy Handling

On-demand power steering with low-input torque, a small steer tiller wheel and tiller knob provide exceptional operator control with minimum effort.



Sweet Savings

From reducing energy consumption to minimizing maintenance costs and maximizing productivity, the SCXB is designed and built to lower your operating costs and improve your bottom line profitability.



1,200
2,400

Low Maintenance

Extended major service intervals of 1,200 and 2,400 hours mean more uptime with less time, effort and money expended on maintenance.

Conserve Your Energy

With its standard Auto Power Off feature, power is turned off to the SCXB if it remains idle for a pre-set period of time. (Factory programmed at 15-minutes, but adjustable from 1–60 minutes.)

The Brake You Need

Our low maintenance brake only needs inspection every 12 months or 2,400 hours.

IP65 Rated Sealed Controller

The controller is fully sealed to lock out dirt and debris that can harm performance or contaminate internal components. Highly reliable non-contact switches and sensors also reduce maintenance requirements.

- 1 Plugging
- 2 Operator Presence
- 3 Neutral Brake
- 4 Brake Pedal

More Power To You

Advanced regenerative technology reclaims power from four different operations — lowering power consumption, extending operating hours, reducing component wear and keeping your equipment out of the charging bay.

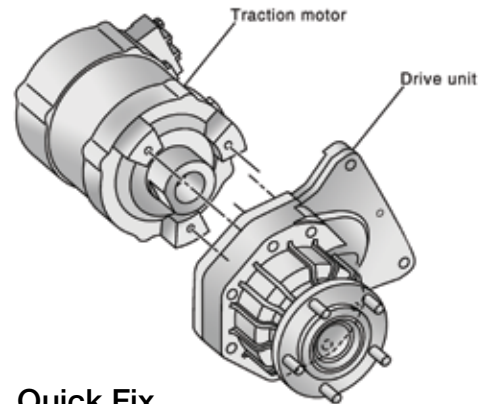

Quick Fix

The modular design of the powertrain speeds and simplifies maintenance. The **gearbox and motor can be removed, serviced and replaced as a single unit** — without removing the mast.



Battery Rollers

Features include standard battery rollers — and an optional battery gate warning option.

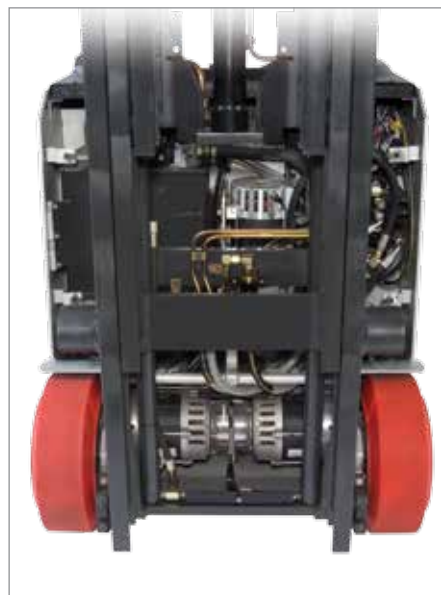

Quick Access

Service points are easily accessible through removable top and front panels for speed and ease of maintenance.



On-Board Diagnostics

On-board diagnostics and truck service history are available through the meter panel for quick troubleshooting — resulting in less downtime and increased productivity. **No tablet, laptop or handset tool is required.**



Play It Safe



The SCXB Series incorporates the latest technology to improve confidence and security in every aspect of our trucks within your operation.



Custom Performance & Secure Access

Up to five different, customized performance profile settings can be quickly and easily entered through the meter panel. PIN codes help ensure access is only available to qualified operators and the settings are matched to the abilities of each driver.



Operator Presence Pedal

Divider Bar

Brake Pedal

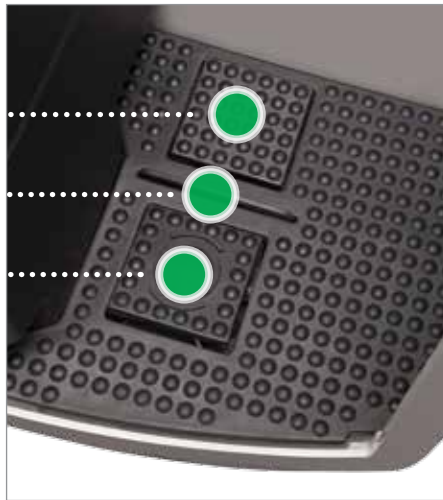

Auto Park

There's no need to set a separate brake because the **parking brake is automatically applied** when travel speed is at 0 and no directional command has been given — or when power to the truck is removed. A divider bar between the pedals ensures both feet must be in the compartment and the operator is in a safe operating position.



Soft Mode

To promote more confident load handling at higher lift heights, the SCXB features a “Soft Mode” performance setting to reduce the possibility of load shifting. Automatically activated when the mast is raised beyond the first stage (or at approximately 47" for a two-stage mast), this design reduces travel, lift, tilt and sideshift speeds; restricts tilt angle; engages tilt interlock and vertical tilt stop; and reduces regeneration braking.



Controlled Rollback With Ramp Hold

If the travel control is returned to neutral while traveling on a ramp, the controller will reduce and stop movement down the slope. When coming to a stop on a ramp, the SCXB controller will apply motor torque to maintain position on the slope, until the automatic parking brakes apply.



Operator Presence

A standard Operator Presence system requires that both the brake and operator presence pedals are depressed to operate. The SCXB offers plenty of room to fit even large work boots comfortably.



Control Freak

Whether it's restricting access to the trucks, regulating the speed at which they travel or limiting operating costs, SCXB Series forklifts provide you with the control you need to manage your operation easily, effectively and completely.

The Ultimate In Control

Through the meter panel, you can:

- Control access through individual PIN codes
- Customize performance settings to individual operators
- Set speed/acceleration parameters
- Select the optimal performance mode

And gain access to a wealth of vital information to manage your operation including: error codes; operating hours; service history; truck status; and diagnostics.

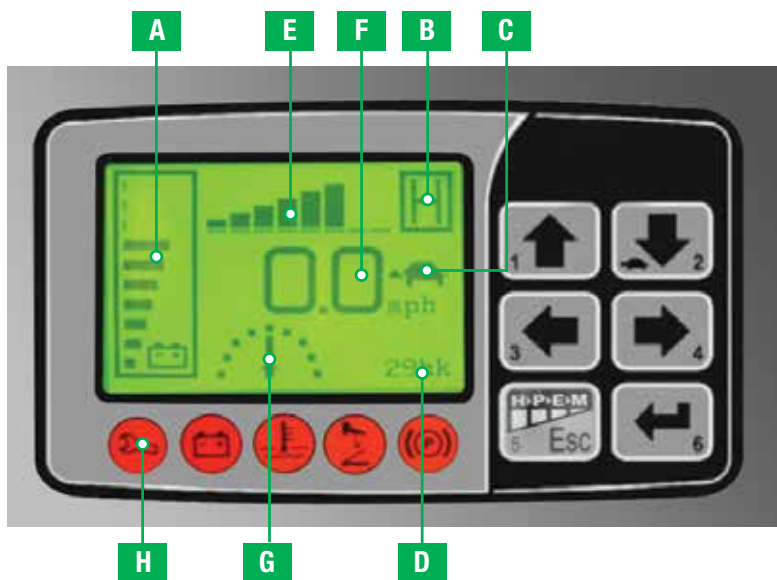

- A** Battery Capacity
- B** Performance Mode
- C** Soft Mode
- D** Hour Meter
- E** Acceleration
- F** Speedometer
- G** Wheel Position
- H** Warning Indicators

BARRETT

by **UNICARRIERS**



Putting Power In Your Hands

Ergonomically designed and intuitive to operate, the multi-function control handle offers simultaneous control of drive, lift-and-lower, horn and auxiliary hydraulic functions.

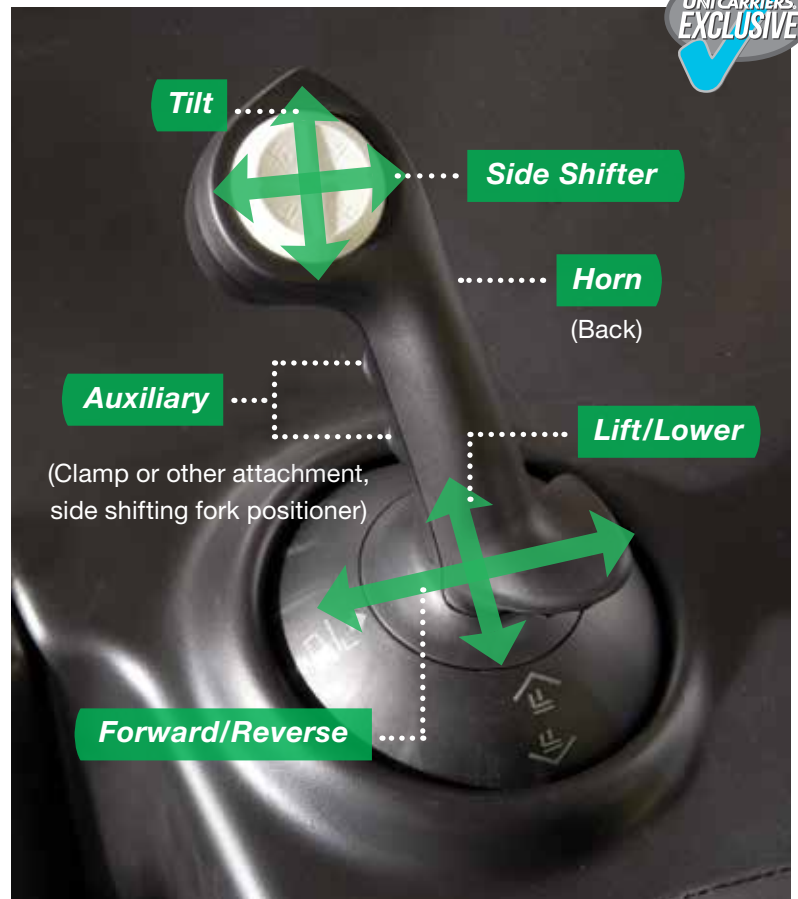

Turn Control

For exceptional maneuverability, the inner wheel counter rotates, and travel speed and acceleration are restricted while turning.





Make It Yours

Unlike competitive brands, Barrett by UniCarriers trucks come standard with the most essential and popular features and accessories. In addition, we offer a complete menu of additional options that allow you to customize your forklift to fit your specific workplace environment, operations and business objectives. On these pages, you'll find available options that are both innovative and economical — but it's only a portion of what we offer. So if you don't see what you're looking for here, call your authorized dealer for more options.



• Rear Strobe Light



• Front Work Lights



Fan & Lighting Package

Fan and compartment light are mounted on the overhead guard canopy for operator comfort & convenience.



Fire Extinguisher

2.5 lb. ABC type — mounts within easy reach of the operator.



Cushioned Knee Pad

Provides greater operator comfort, especially during long work shifts.



Battery Gate Interlock Switch

Helps prevent or restrict truck travel if the battery gates are not installed correctly. Operator is notified through an error code on the meter panel.



Side Shifter

Operators will experience greater efficiency due to fewer required moves when storing and retrieving loads. Integral or hang-on design available.

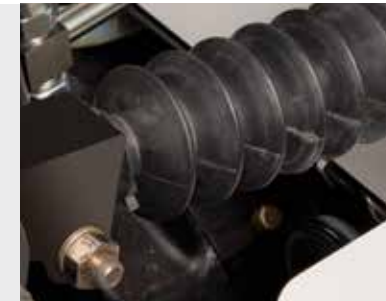

Tilt Cylinder Boots

Added protection against condensation, dirt and dust.

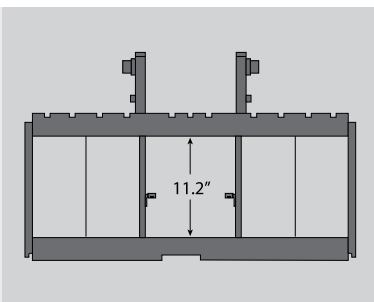

High Visibility Carriage

Offers 38% increased vertical open space between the carriage bars for enhanced visibility.



Lower Overhead Guard

Low 83.3" profile for more confined, height-restricted areas. Other heights available.



Freezer Package

For operating in environments as low as -22°F (-30°C) — includes special hydraulic oil and tilt cylinder boots.

Option Availability

● Standard ○ Optional

VEHICLE MANAGEMENT	
AC TECH motor controller system	●
AC dual drive motors and AC hydraulic pump motor	●
Interactive LCD meter panel with adjustable performance settings	●
Operator security PIN access	●
Controlled rollback	●
3 preset performance modes (economy, normal, high)	●
1 manual (custom) performance mode	●
On-board diagnostics, self-test and coded service history	●
Low battery lift interrupt system	●
BATTERY / ELECTRICAL	
Battery compartment rollers and side gates	●
Battery gate interlock switch	○
Emergency power disconnect switch	●
Adjustable auto power off	●
Anti-static ground strap	●
BRAKE	
4-mode regenerative braking	●
Electro-magnetic parking brake (automatically applied)	●
MAST	
Auto-mast lock system	●
High visibility carriage	●
HYDRAULIC SYSTEM	
On-demand priority hydraulic power steering with tiller control	●
OPERATOR CONVENIENCES	
Side stance operator compartment	●
Ergonomically sloped floorboard with vibration isolators	●
Multi-function control handle	●
Forward steering (forks leading)	●
Reverse steering (forks trailing)	○
Cushioned floor mat, back and armrest padding	●
Cushioned knee padding	○
Integrated clipboard and amenity tray	●
Low overhead guard	○
Overhead guard mounted LED headlights	○
Rear overhead guard mounted LED work light	○
Operator fan and light package (mounted to overhead guard console)	○
Freezer package	○
Strobe light	○
PROTECTION / SECURITY	
Operator presence system with return-to-neutral & auto mast lock	●
Reduced speeds and tilt above free lift	●
Fire extinguisher	○
Travel alarm (forward, reverse or both)	○

Specifications

MODEL	SCXB30SN	SCXB30N	SCXB35N	SCXB40N
Long Model	S1S1L15NV	1S1L15NV	1S1L18NV	1S1L20NV
Capacity	3,000 lb.	3,000 lb.	3,500 lb.	4,000 lb.
Voltage	36v	36v	36v	36v
Frame	Short	Standard	Standard	Long
Length — in. (mm)	66 (1680)	68.2 (1735)	68.2 (1735)	70.5 (1790)
Wheelbase — in. (mm)	41.8 (1065)	43.9 (1115)	43.9 (1115)	46.3 (1175)
Turning Radius — in. (mm)	52.3 (1330)	54.5 (1385)	54.5 (1385)	56.8 (1445)
Min. Right Angle Stack— in. (mm)	66.3 (1685)	68.5 (1740)	68.5 (1740)	70.8 (1800)
Battery Compartment	38.5" w x 16.3" l x 32" h	38.5" w x 18.4" l x 32" h	38.5" w x 18.4" l x 32" h	38.5" w x 20.8" l x 32" h
Max. Capacity (6-hr.rating)	930Ah	1085Ah	1085Ah	1240Ah
Min/Max Battery Weight — lb.	1885 / 2400	2175 / 2700	2175 / 2700	2460 / 3000



Power, performance and reliability...all backed by the best standard limited warranty in the business!*

- 2 Years
- Unlimited Hours

* Contact Unicarriers Americas for specific details, limitations, and exclusions.

Built Like No Others.
Backed Like Nothing Else.



Quality, performance, reliability and efficiency — we believe that the same attributes that make a great forklift are also essential elements of an exceptional company. As a result we've built an organization that overlooks no detail in manufacturing material handling equipment that delivers the highest level of **performance and value** — and that stands behind our products with comprehensive service and support.

Our products are designed to produce maximum productivity without compromising operator safety. **They're built to exacting standards to maximize uptime.** They're scrupulously tested to ensure strict tolerances are met — and offered by a network of highly skilled, highly professional dealerships committed to customer satisfaction.

And when it comes to the environment, we put the same passion and energy into creating an effective sustainability initiative as we put into engineering our products.

At UniCarriers, our mission is to **continuously move performance standards upward** — and to provide the support you need to **move your business forward.**

SB-SCXB 12-2014
Printed in U.S.A.



UniCarriers® is a registered trademark of UniCarriers Corporation. UniCarriers Americas Corporation reserves the right to make product changes relating to colors, equipment, specifications or available options without notice.

For more information, contact your Barrett by UniCarriers representative.

UNI CARRIERS®

UniCarriers Americas Corporation

UniCarriersAmericas.com