

**NISSAN**  
**FORKLIFT**

by **UNICARRIERS**

# Platinum QX Series

Pneumatic Tire

80 Volt Battery Powered Models



4,000-6,000 lbs. Capacities



# NISSAN FORKLIFT

by **UNICARRIERS**®

Two years. Unlimited hours. It's more than just the best standard, limited warranty in the business.\* It's also a reflection of the advanced engineering and workmanship that go into our forklifts—and the result of more than half a century of bringing innovation and excellence to forklift manufacturing.



## Up Your UpTime

Reliability is key and that's no mistake. Design, engineering and relentless testing are part of our DNA. The result is what we expect and what you demand.



## Comfort Zone

Work comes first, but there are amenities that make the experience more pleasurable. And happy drivers are statistically more productive.



## Power & Performance

Our 100% AC motors and controller system and intuitive designs allow you to move in a way that makes sense. The resulting productivity saves you time, money and driver mishaps.



## Sweet Savings

Our low cost of ownership is something you can take to the bank. We take our commitment to delivering value seriously because we know you do.

The power of an internal combustion engine without the emissions. Advanced features that drive down costs as they drive up productivity. A tough, rugged forklift that's built for maximum operator comfort. You get all of this – and more – with the QX Series. So, if you want a forklift that's better for your operation, better for your operators, and better for the environment, you want a QX Series truck.



The QX Series combines the performance of an engine-powered truck with the benefits of zero emissions and is ideal for a variety of applications, including:

- Food products companies
- Warehouse & distribution
- Manufacturing

Be sure to look for the symbols shown above throughout this brochure for features available only on Nissan Forklift by UniCarriers equipment or that provide a proven performance advantage far above any you will find on other forklift brands.



### Play It Safe

Your employees' well-being is an imperative. Standard protection features mean greater confidence in the workplace.



### Control Freak

Our advanced features give you control to promote operator security, manage your productivity, contain costs, or do all these things at once.



### Make It Your Own

Choose from a variety of options to customize your ride. If you don't see what you need, contact your authorized Nissan Forklift by UniCarriers dealer for help.



To learn more, and find a dealer near you, visit [UniCarriersAmericas.com](http://UniCarriersAmericas.com)



# Up Your UpTime

When it comes to keeping your operation up and running, the QX Series offers you significant advantages, beginning with 100% AC-powered, brushless drive and hydraulic motors that feature fewer parts for greater reliability. The QX also cuts downtime nearly in half with major maintenance required only every 1200 hours. Throughout the QX truck you'll find innovative and proven systems to help you maximize uptime, while minimizing cost.



## Thermal Sensors Help Prevent Overheating

The QX features thermal sensors to help protect the motor and controller systems. If overheating occurs, a warning flashes on the LCD screen alerting the operator, then travel and lift speeds are reduced. The information is also automatically locked into the truck's service history to assist technicians and speed servicing.



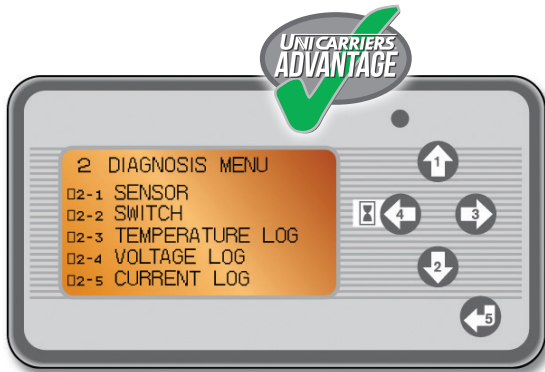

## Self-Diagnostics Deliver More Uptime

An **integrated self-check** provides immediate truck status. The intuitive dialogue display, with its accessible service history, **reduces troubleshooting time**, so your unit is back in operation faster. Everything is done through a smart LCD panel that eliminates the need for a laptop, tablet or handset tool.

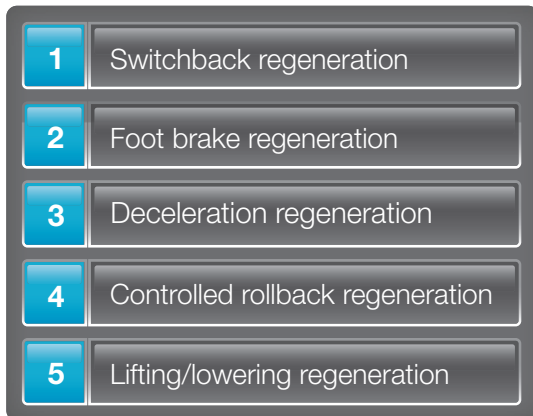

## Five Regenerative Functions

The QX offers five regenerative technologies to reduce power consumption and deliver longer operating hours. Regenerative braking further improves uptime by reducing operator effort and component wear for longer service life.

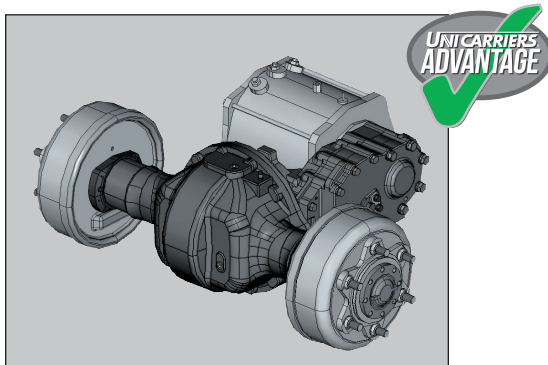

## Dependable Drive Units

Our AC induction drive motor has fewer parts to maintain and is perfectly matched to a simple, yet highly efficient, transmission. The result? Greater dependability and higher performance. The drive motor is also mounted under the floorboard, inside the truck's frame, for added protection against debris and damage.

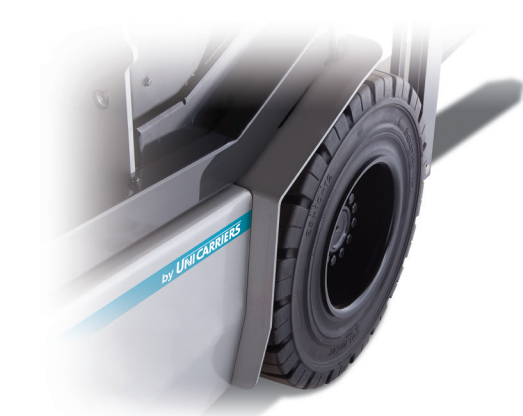

## Solid Pneumatic Tires Keep You Rolling

The solid pneumatic tires on the QX are **more resistant to wear or damage** caused by dock plates or pavement and won't go flat. **Wide drive tires are standard** on the 6,000 lb. model, and optional on smaller capacities.



# Comfort Zone

When it comes to productivity, operator comfort is not a luxury, it's a necessity. That's why the QX Series features a spacious compartment with more than 41" of headroom and ergonomic advantages that reduce fatigue, simplify operation, enhance visibility, and allow precise handling. All to drive up the performance of your operators and the profitability of your operation.

## We Thought Of Everything



While other forklifts place the battery connector right under the operator's legs, on the QX it's positioned under the hood and away from the operator for more legroom. There's even a rubber floor mat for greater comfort and vibration absorption.



## Clean, Quiet Performance

With its 80-volt motor, the QX Series delivers a quiet ride and zero emissions for a better operator experience, and an improved work environment for everyone in the area.



## Full Suspension Seat

For enhanced comfort and shock absorption, the QX comes standard with a full suspension seat that features weight and back-angle adjustment as well as a retractable seatbelt and hip restraints. Cloth or optional vinyl seating is available.



## Sure Footed Control



The QX Series features an open floorboard area with generous foot room. Plus, switching between the brake and accelerator is easier and safer thanks to our **heel-to-toe concept** that assures the pedals are at the same height when released.



## Right At Your Fingertips

An **adjustable armrest with electronic fingertip control** is available as an option. Choose between a single joystick for simultaneous lift/tilt or a multi-lever design.

Optional **auto-tilt leveling** that brings the forks horizontal at the touch of a button, enabling quick, easy positioning of the forks for greater efficiency, is available with the multi-lever control.



## In Control

For precise load handling, the hydraulic controls are ergonomically placed and deck mounted. There is also an automotive-style forward/reverse control lever with integrated auto-return turn signals and headlight switch.

## Steering You In The Right Direction

The QX features on-demand electronic power steering for easier, more responsive handling. Plus, the steering column has an infinitely adjustable tilt angle for truly customized comfort.



# Power & Performance

When it comes to lift & travel speeds, the QX Series delivers **superior performance, comparable to engine-powered trucks**. Thanks to its 80-volt technology it offers all of this power without emissions. And, because of its higher voltage, the QX requires less amperage to complete the same amount of work as 36- or 48-volt designs. So, compare a QX to other brands and you'll see, there's simply no comparison.



**The Power To Lift Your Whole Business**  
Our rugged mast features rolled steel channels and thick inner rails for **increased capacity retention**. The side thrust rollers on the fork carriage are also easily accessible for simpler carriage adjustments.



## Superior Performance

Faster lift speeds. Faster travel speeds. We compared the performance of a QX Series truck with its leading competitors, and when it comes to productivity-enhancing performance, nothing delivers like a QX truck. That means you can do more – more quickly, more efficiently, and more profitably.

### Lifting Speeds

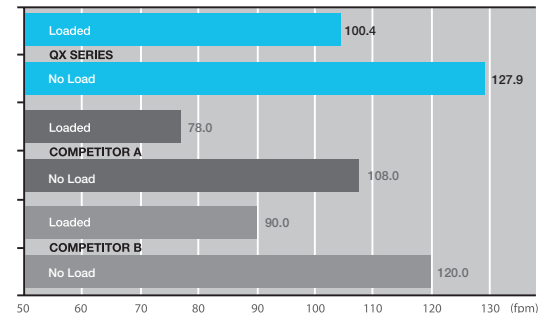

### Travel Speeds

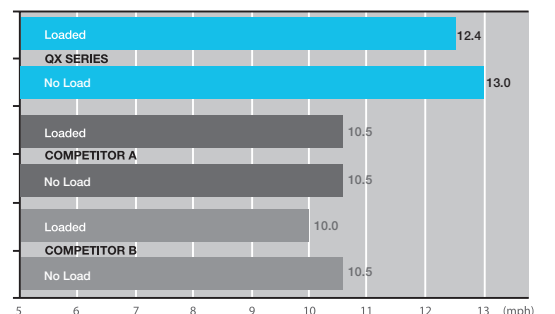

## 3+1 Performance Modes = Greater Productivity

The QX Series features adjustable settings to optimize performance based on the application, work environment or operator experience. Choose from the three factory-set modes (below) to quickly customize your lift truck. The QX also has a manual mode to create unique settings, finely tuned for your operator and operation.



### Economy Mode

Extended operating hours achieved with only slightly reduced performance



### Performance Mode

Offers mid-range settings for normal performance needs



### High Performance Mode

To reach maximum desired performance



### Manual Mode

Provides access to customize performance parameters



## Powerful Pneumatics To Tackle Your Tough Jobs

The QX Series features a wider stance and **higher under clearance** for applications that have rough ground conditions or flooring, and yet has a **small enough turning radius** to work in areas where a cushion tire forklift would normally be used.

Choose from four models ranging from 4,000 to 6,000 lb. lifting capacities, including larger battery compartment models for extended work intervals.



## Make Fast Work Out Of Your Work

The QX Series' 80-volt technology delivers adjustable acceleration and **productivity-enhancing speeds comparable to engine-powered trucks**. Since the higher voltage system requires less amperage to get the job done, there's less potential for heat build-up, resulting in longer component life.



# Sweet Savings

The QX Series saves you money in all kinds of ways. The positioning of its motors shields them from debris and damage – saving you money. The 80-volt system reduces possible heat build-up for longer component life. Saving you even more money. The AC motor features fewer parts. Saving you money yet again. Wherever you look on a QX, you'll find money-saving innovations. So, considering how economical a QX is, can you afford not to own one?



## Avoid An Energy Crisis

Industrial batteries can be a significant part of your operational expenses. So, **QX trucks incorporate power saving features to optimize battery usage** – delivering better returns on your equipment investment:

- An auto power-off cuts the electrical system if the truck sits idle. You'll find this standard feature on all QX trucks, and it can be adjusted for up to 60 minutes before powering down the vehicle.
- Our advanced regenerative braking technologies reclaim energy using five efficient operations, contributing to lower power consumption and increased operating hours. This also results in reduced heat generation and component wear, for even greater long-term savings.
- The on-demand power steering system draws battery power only when required.



## Fewer Serviceable Parts Mean Fewer Expenses

The **100% AC-powered system** on the QX features brushless drive and pump motors and a single contactor. The steering system is electronically controlled and powered through the hydraulics, thus eliminating the need for – and added expense of – a separate steering motor.



## Programmed Savings

With the QX Series, the accelerator-off and switch-back regenerative braking force can be adjusted. This results in reduced energy consumption and extended brake life.

You can also program in maximum travel speeds and tailor performance based on application and driver skills.

Plus, the integrated self-diagnostics provide immediate truck status and make **troubleshooting simpler and faster**. All without the need for a laptop, tablet, or handset tool.



## Our Overhead Guard Reduces Your Overhead

Beyond ample headroom, the five-piece overhead guard takes **75% less time to make needed replacements** versus most competitors' single-piece, welded-on guards. That cuts downtime and costs.

## Extended Maintenance Schedule

With the QX Series, major maintenance is required only every 1,200 hours. So you spend more time working – not working on – on your trucks.



To learn more, and find a dealer near you, visit [UniCarriersAmericas.com](http://UniCarriersAmericas.com)



# Play It Safe



Safety is everybody's business, and when it comes to helping you create a safer operation, the QX Series is all business. Throughout a QX, you and your operators will discover innovative technology and essential systems that will help protect your staff, your inventory and your facilities. All without sacrificing performance. It's a safe bet, you'll get more out of a QX truck.

## Greater Stability



The QX achieves a **low center of gravity** by placing the battery deeper into the truck. This design advantage results in **outstanding stability and balance with greater capacity retention during high lifts**.

## Visibly Superior

All QX Series models are equipped with the following standard features:

- Overhead guard mounted headlights
- Side view mirrors
- Turn signals
- Rear combination turn, stop and back lights
- Rear work light



## Operator Presence System

This comprehensive system includes a **seat-actuated power interrupt with mast-lock**, automatically preventing lift and tilt operations if the operator leaves the seat. The **return-to-neutral** feature minimizes forklift movement if the operator leaves the truck while still in gear. Other audible and visual warnings come standard, including a **seatbelt alarm**.



## Forward Thinking Back Up Alarm

Our back-up alarm provides plenty of notice to pedestrians and other drivers in the area. For applications with varying noise levels, there is an optional self-adjusting alarm that adjusts sound volume based on ambient noise levels.



## Parking Alarm

As part of the Operator Presence System, a warning buzzer alerts the driver if he leaves the seat without first setting the parking brake.



# Control Freak

The QX Series is all about control – it starts with controlling costs and extends to giving operators complete command over their vehicle, their work, their environment, and your facilities. From logically positioned controls to precise, consistent truck movements to detailed information at your fingertips, the QX always puts you and your operators in the driver's seat.

## Information At A Glance

The interactive meter panel on the QX provides operators and technicians with a wealth of information through its LCD warnings and readouts. Using the numbered function keys you can program settings, perform maintenance tasks, and access service history.

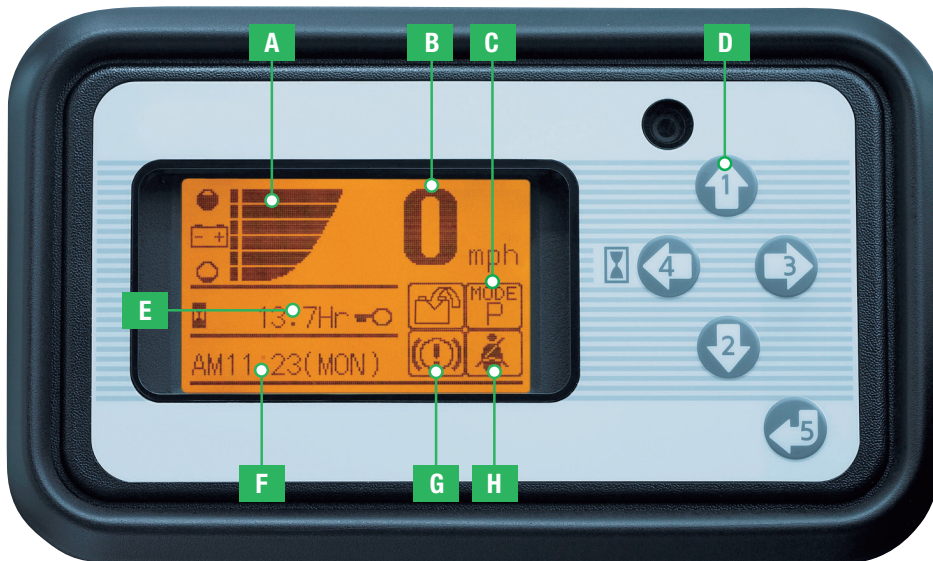

- A** Battery discharge indicator
- B** Speedometer
- C** Power mode
- D** Function keys
- E** Hour meter reading - 4 operational modes
- F** Clock/alarm & acceleration level
- G** Parking brake warning
- H** Seat belt warning

## Ramp Up The Power

Tough applications, including frequent ramp climbing are no challenge to the QX Series. For maximum control, it includes a standard adjustable **controlled rollback** feature that restricts truck speed when descending a ramp. It's activated when the accelerator pedal is released and eliminates the need for continuous brake pedal force by the operator.



## Password Protected Security

Using a PIN code/password entry feature helps **assure that only qualified drivers are operating your QX**. Up to five unique performance settings can be created, based on application and/or individual operator skill level.



## Customized Accelerator Sensitivity

Our unique system lets you **set the accelerator pedal's sensitivity so you can match it to operational requirements, applications, or a driver's skill level**. You can set a slower acceleration for precise handling in high traffic areas, or a faster response time for operations with longer runs.

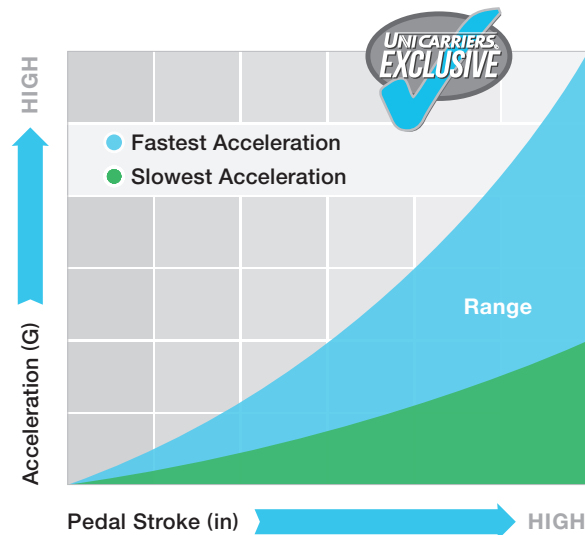

## Keep Things On The Straight & Narrow

Our optional steering synchronizer uses a sensor that monitors the steering wheel and tire angle so the steering knob is always returned to the same position. This **assures accurate and consistent coordination of the steering wheel and tires** for precise steering operation.

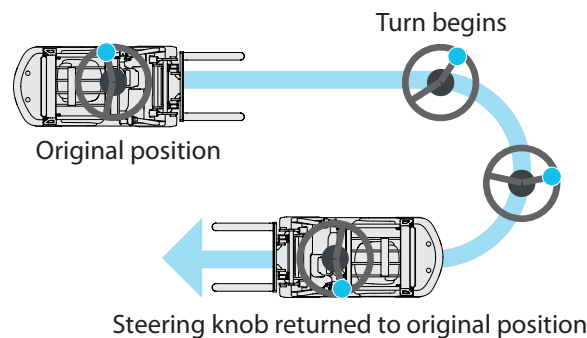

## Small Diameter Steering Wheel

Our small diameter steering wheel features a standard spinner knob for maximum maneuverability and operator confidence.





# Make It Your Own

Already loaded with standard features, a QX truck can also be customized for your unique applications and needs. You can choose from a variety of performance enhancing options. If you don't see what you need, contact your authorized Nissan Forklift by UniCarriers dealer for more options.



• Strobe Light



• Fire Extinguisher



### Steering Synchronizer

Sensor monitors steering wheel and tire angle, adjusting the steering wheel knob for precise turns and steering operation.



### Fingertip Controls

Increase operator productivity with ergonomic hydraulic controls. Choose single joystick or multiple lever designs.



### Pedestrian LED Blue Spot Light

Reverse driving actuates an optional blue spotlight to illuminate the floor, for advanced visual warning.



### Sideshifter

Operators will experience greater efficiency due to fewer required moves when storing and retrieving loads. Choose from integral or hang-on designs.

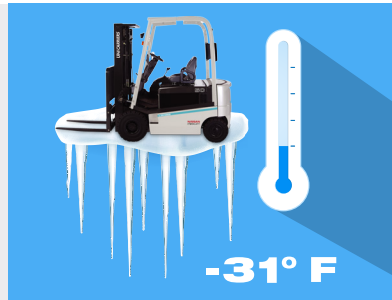

### Freezer Package

For operating in cold storage and freezer environments in temperatures as low as -31° F (-35° C) – includes special hydraulic oil and steel tubing, rubber floor mat and cylinder boots.

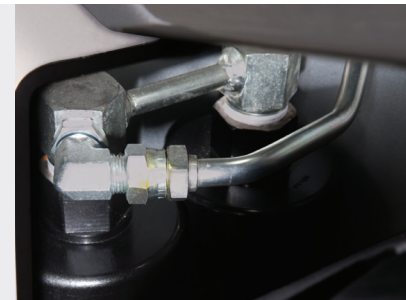

### Accumulator

Ideal with fragile loads. Feature absorbs shocks transmitted while driving over uneven or cracked floors to make load handling and travel smoother.



### Polycarbonate Overhead Guard Cover

Prevents small debris from entering the operator compartment through the overhead guard.



### Lower Overhead Guard

An 83.7" height design for more confined, height-restricted areas.



### Higher Steering Wheel

High or low steering columns to enhance operator comfort and productivity.

# Option Availability

● Standard    ○ Optional

## VEHICLE MANAGEMENT

AC TECH motor controller system	●
Interactive LCD meter panel with adjustable performance settings	●
Operator security PIN access	●
3 pre-set performance modes (Economy, Normal, High)	●
1 Manual (custom) performance mode	●
On-board diagnostics, self test & coded service history	●
Low battery Lift Interrupt System	●
Controlled rollback	●

## BATTERY/ELECTRICAL

80 Volt system	●
----------------	---

## BRAKE

Hand-applied parking brake with warning buzzer	●
5-mode regenerative braking	●

## HYDRAULIC SYSTEM

Deck-mounted control levers	●
Electronic fingertip control levers (separate lift and tilt or single lever)	○
Auto-fork leveling*	○
Accumulator	○

## OPERATOR CONVENIENCES

Full suspension seat with weight adjustment	●
Overhead Guard-mounted headlights	●
Glass rearview mirrors	●
Rear combination light package (turn, stop, back-up)	●
Rear work light	●
Strobe light	○
Steering wheel with spinner knob	●
Magnetic convenience box	○
Low overhead guard (83.7")	○

## PROTECTION/SECURITY

Operator Presence System with return-to-neutral & seat-actuated auto-mast lock	●
Fire extinguisher	○
Back-up warning alarm	●

Some options may require additional lead time. Consult your local authorized Nissan Forklift by UniCarriers Dealer for details.

\*Only available with fingertip control option with separate lift and tilt levers. Other restrictions apply.

# Specifications

MODEL	QX40	QX50	QX50L	QX60
Capacity lbs (kg)	4,000 (1815)	5,000 (2265)	5,000 (2265)	6,000 (2720)
Voltage	80	80	80	80
Max Travel Speed Loaded/Unloaded mph (km/h)	12.7/13.0 (20.5/21.0)	12.4/13.0 (20.0/21/0)	12.4/13.0 (20.0/21/0)	12.4/13.0 (18.5/21.0)
Max Lift Speed – loaded fpm (mm/sec)	100.40 (510)	92.5 (470)	92.5 (470)	88.6 (450)
Max Lift Speed – unloaded fpm (mm/sec)	127.9 (650)	127.9 (650)	127.9 (650)	108.3 (550)
Min. Outside Turning Radius in (mm)	78.4 (1990)	78.4 (1990)	84.3 (2140)	84.3 (2140)
Overhead Guard Height in (mm/sec)	88 (2235)	88 (2235)	88 (2235)	88 (2235)
Battery Compartment Size* in (mm)	28.18 x 40.66 x 31.65 (715 x 1030 x 800)	28.18 x 40.66 x 31.65 (715 x 1030 x 800)	33.85 x 40.66 x 31.65 (855 x 1030 x 800)	33.85 x 40.66 x 31.65 (855 x 1030 x 800)
Battery Ah - min / max	480 / 620	480 / 620	600 / 775	600 / 775



Power, performance and reliability...all backed by the best standard limited warranty in the business!\*

- 2 Years
- Unlimited Hours

\* Contact UniCarriers Americas for specific details, limitations, and exclusions.

Built Like No Others.  
Backed Like Nothing Else.



**Quality, performance, reliability and efficiency** — we believe that the same attributes that make a great forklift are also essential elements of an exceptional company. As a result we've built an organization that overlooks no detail in manufacturing material handling equipment that delivers the highest level of performance and value — and that stands behind our products with comprehensive service and support.

Our products are designed to produce maximum productivity without compromising operator safety. They're built to exacting standards to maximize uptime. They're scrupulously tested to ensure strict tolerances are met — and offered by a network of highly skilled, highly professional dealerships committed to customer satisfaction.

And when it comes to the environment, we put the same passion and energy into creating an effective sustainability initiative as we put into engineering our products.

At UniCarriers, our mission is to continuously move performance standards upward — and to provide the support you need to move your business forward.

**SB-QX 02-2015**  
**Printed in U.S.A.**



UniCarriers® is a registered trademark of UniCarriers Corporation. UniCarriers Americas Corporation reserves the right to make product changes relating to colors, equipment, specifications or available options without notice.

For more information, contact your Nissan Forklift by UniCarriers representative.

**UNI CARRIERS**®

UniCarriers Americas Corporation

[UniCarriersAmericas.com](http://UniCarriersAmericas.com)