

TCM

Large-size Forklift Trucks

25-30 ton

FD250-3 FD300-3



Successor to Our Top Product

The Long-time best-selling products prove the "trust" of users. The newly upgraded and redesigned FD250 and FD300 large forklift trucks have now debuted in global markets.

The 25-ton TCM forklift truck has been ranked as the best-selling product in its class for more than seventeen years since its debut in 1989. Our dear customers' patronage of this product is undoubtedly due to its superior function - durability and leading technologies as well as TCM's detailed knowledge and extensive experience at customers' worksites. TCM is very proud to release the advanced FD300 following the recently redesigned FD250. The new FD250 and FD300 forklifts — equipped with an engine compliant with Japanese 2nd stage emission controls, wider front and rear visibility, and 4-speed automatic transmission — are indeed the leading "Comfortable Forklift Trucks" for this age of advanced material handling.

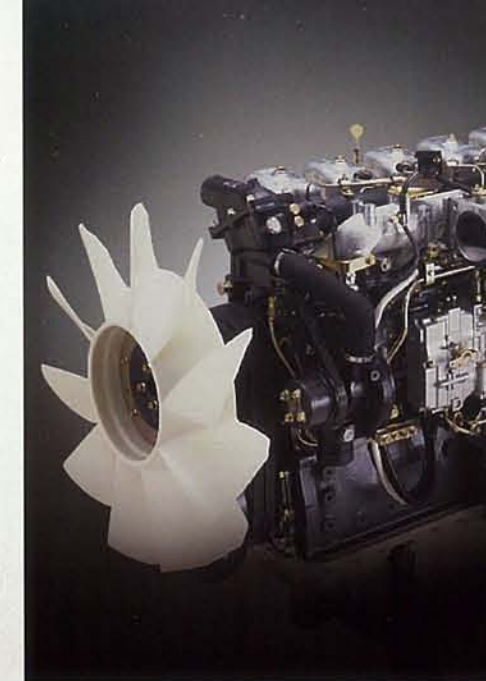

Newly adopted engine, clearing stringent environmental regulations.

The mounted 165kW inter-cooler turbo diesel engine is the largest capacity in its class, with sufficient power able to conduct continued rigorous work.

Total displacement **11,940_{cc}**

Rated horsepower **165_{kw}/2,100_{rpm}**
224_{ps}/2,100_{rpm}

Maximum torque **980_{N·m}/1,400_{rpm}**

FD300 forklifts have debuted in response to the recent revision of the 20'-container weight standard (up to 30,480kg) by ISO.



The photo shows both FD250-3 and FD300-3 with side shifters fork positioners.

Operator-friendly and comfortable cabin space designed with thoughtful consideration of the operator's difficult job.

Forklift Trucks Comfortable for Operators

Superb ride and low vibration in the cabin due to the adoption of a floating cockpit and deluxe seat.

Industry top-class lifting speeds

FD250 360mm/s (without load) 330mm/s (with load)

FD300 280mm/s (without load) 250mm/s (with load)



FD250
330/360
mm/s
(with load / without load)

FD300
250/280
mm/s
(with load / without load)

Deluxe seat
Pillar-less cabin
Viscous-mount low vibration system (silicon oil filled)



Low-noise, lower vibration cabin

A liquid-filled rubber mount (Viscous-mount) between the driver's seat and the frame. In addition, an integrated rubber mount in the hydraulic part reduces noise and vibration significantly.

Large-capacity air conditioner (standard equipment)

Very pleasant and relaxing space in the cabin due to a large-capacity air conditioner.

Cooling Efficiency **4.7kW**

Pillar-less cabin and compact meter panel

Excellent visibility achieved by absence of front and rear pillars. Compact meter panel further contributes to clean, wider front visibility.

Integrated switch panel board

Recognition of worksites and operating efficiencies is substantially improved due to the compactly integrated layout of all switches on the right side of the operator.



Flat and wider step board

Easier and safer entry and exit.

Improved rear visibility

Rear visibility is largely improved due to reshaping of the counter weight.



Single steering cylinder system

Deluxe multi-functional seat as standard equipment

Well-cushioned deluxe seat with various functions such as reclining, forward/backward sliding, smooth swiveling, upward/downward adjustment, and adjustable armrest position.



Closed wet-disc brakes

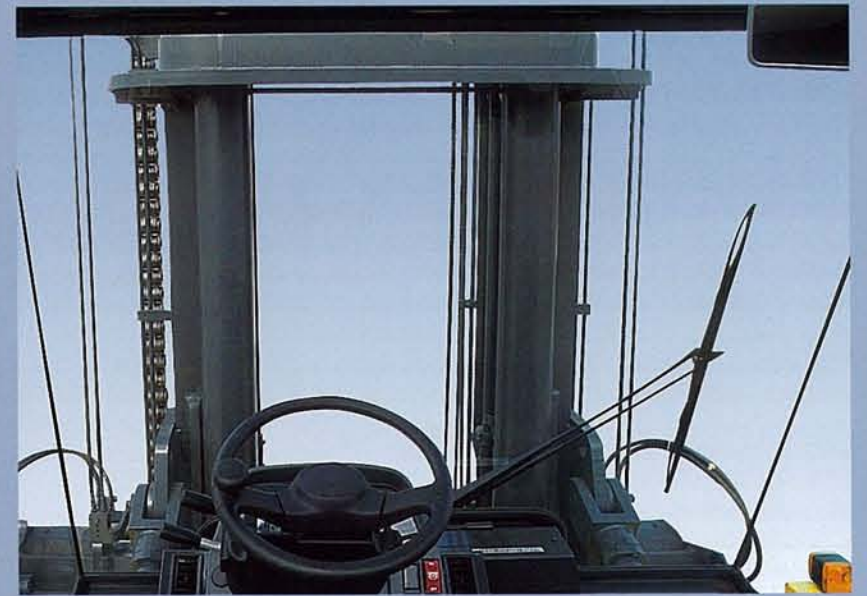



Simpler operation reduces physical fatigue even in harsh working conditions.

Operation with higher work efficiency as well as enhanced safety

These large forklift trucks are capable of quickly, easily, and powerfully performing very heavy load operations such as handling metal materials and marine containers.



4-speed automatic transmission (duo-stick system)

Possible to select either 1st gear → 4th gear, or 2nd gear → 4th gear by automatic transmission, similar to passenger cars. The new duo-stick lever system can perform backward and forward shifting while handling the steering wheel.

D(P)	First ⇔ Second ⇔ Third ⇔ Fourth
D(E)	Second ⇔ Third ⇔ Fourth
First gear	Fixed at the first speed
Second gear	Fixed at the second speed

(P) Power mode drive (E) Economy mode drive

Steering wheel with smaller turning radius

Possible to change cargo-handling modes very easily due to the light and sharp hydraulic steering system.

Reduced steering operation force
1.0kg
3.8 turns

(for FD250)



Hydraulic pilot-type control valves newly adopted for operation levers

Possible to operate and control the vehicle with light touches of the hydraulic assist lever and armrest. Difficult operations can be performed by fingertip maneuvers, as well.

Lever-handling force reduced by **8.2% - 0.7kg**

- ① Lifting ② Tilting ③ Side Shifter(optional)
- ④・⑤ Fork Positioner(optional)

New electronic parking system



Easy to apply parking brake electronically. In addition, the electronic brake is automatically switched on when the engine halts, avoiding negligent braking when the vehicle stops.

Larger fuel tank

Extended refueling interval contributes to work efficiency.

600 liters



Easier vehicle inspection and maintenance

Both inspection and maintenance of the engine can be easily performed, as the hood opens widely and the side panels open three ways. Moreover, a centralized oil supply system for the mast and a hinged wide cover for the battery box were adopted. Furthermore, inspection and cleaning of the air-cleaner, attached to the upper part of the hood, can be accomplished conveniently.

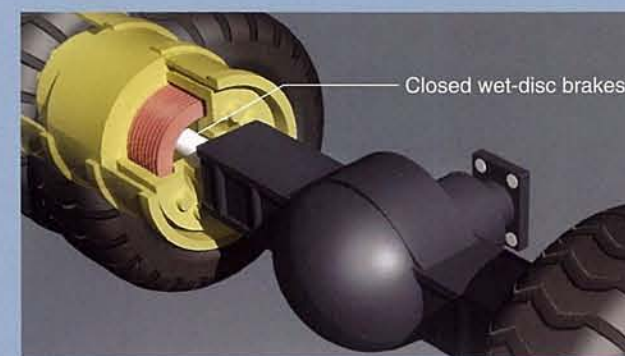

Closed wet-disc brakes

A newly adopted brake with compulsory cooling system. Stable braking and reduced maintenance cost compared to the lining friction loss of a drum braking system.

Full-power braking system

A full-power braking system has been adopted, eliminating the need for air pressure circuit and brake oil, thereby improving maintenance costs dramatically.

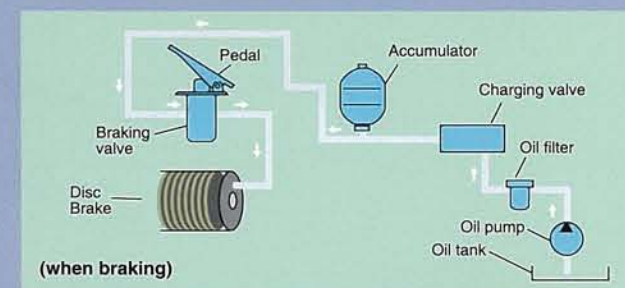

Single steering cylinder system

The single steering cylinder system makes stationary steering easy, resulting in comfortable steering maneuverability.





TCM retains the right to change these products and specifications without incurring any obligation relating to such changes.
These products and specifications are subject to change without notice.
Photos and illustrations may or may not include optional equipment and accessories.
Features and specifications may vary depending on markets.

Manufactured by

TCM

TCM CORPORATION

1-15-5 Nishi-Shimbashi, Minato-ku,
Tokyo 105-0003 Japan

TEL: +81 3 3591 8176

FAX: +81 3 3591 8152

www.tcmglobal.net

Distributed by

TCM

Large-size Forklift Trucks

25-30 ton

SPECIFICATIONS

FD250-3 FD300-3



STANDARD SPECIFICATIONS

Characteristics		TCM		TCM		
1	Manufacturer			TCM		
2	Model	FD250-3		FD300-3		
3	Load Capacity	kg	25000	kg	30500	
4	Load Center	mm	1220	mm	1220	
5	Power Type	Diesel		Diesel		
6	Operator Position	Seated		Seated		
7	Tire Type	Front/Rear	Pneumatic		Pneumatic	
8	Wheels(x=driven)	Front/Rear	2x / 2		2x / 2	

Dimensions		TCM		TCM	
9	Maximum Fork Height	mm	A	3000	3000
10	Free Lift	mm		0	0
12	Overall length : with forks	mm	C	8750	9135
13	Fork Size	L x W x T		2440 x 310 x 105	2440 x 330 x 108
	Fork Spread(Outside)	Max. / Min.	B	2750 / 950	2750 / 1250
14	Tilt Angle	Fwd. / Bwd.	deg	6 / 12	6 / 12
15	Length to Fork Face		mm	6310	6695
16	Overall Width		mm	3070	3460
17	Mast Lowered Height		mm	3750	3750
18	Mast Extended Height		mm	5250	5250
19	Cabin Height		mm	3600	3650
	Overhead Guard Height		mm	-	-
20	Operator's Seat Height		mm	2400	2460
21	Turning Radius(Outside)		mm	5900	6310
22	Load Distance (Centerline of front axle to front face of forks)		mm	985	1070
	Rear Overhang		mm	925	1025
23	Intersectina Aisle		mm	5000	5330

Performance		Travel speed (Fwd. / Rvs.)		1st		2nd		3rd		4th	
24	Speeds	km/h	mm/sec	7.5	7.0	5.8	5.3	13.0	12.0	10.1	9.2
				21.0	19.5	16.1	14.9				
				34.0	32.0	26.1	24.4				
				330	250						
25	Lifting	mm/sec	360	280							
			400 - 600	400 - 600							
26	Lowering	mm/sec	400 - 600	400 - 600							
			163	197							
28	Max. Drawbar Pull	kN	118	148							
			22	20							
30	Max. Gradeability*	%	27	26							
			22	20							

Weight		kg		kg	
32	Total Weight	34150		43440	
33	Weight Distribution	Full Load	Front	53400	67480
			Rear	4710	6460
		No Load	Front	17250	21620
			Rear	16900	21820

Chassis & Wheels		Number		Front / Rear		4 / 2		4 / 2	
35	Tires	Front		14.00 - 24 - 24PR(ID)	16.00 - 25 - 32PR(ID)				
36	Size	Rear		14.00 - 24 - 24PR(ID)	16.00 - 25 - 32PR(ID)				
37	Wheelbase		mm	4400	4600				
38	Tread	Front	mm	2200	2440				
		Rear	mm	2300	2530				
39	Overhead Clearance		mm	1115	1115				
	Hood Height		mm	2060	2135				
	Drawbar Height		mm	785	850				
	Step Height / Floor Height		mm	-	-				
40	Underclearance	Min. without Load	mm	300	300				
41		Center of Wheelbase	mm	330	385				
42	Brake	Service(Foot)		Built in axle - multiple wet disc	Built in axle - multiple wet disc				
43		Parking		Built in mission - wet disc	Built in mission - wet disc				

Engine & Transmission		Voltage / Capacity(5HR)		V / AH		2 x 12 / 108		2 x 12 / 108	
45	Battery								
49	Internal Combustion Engine	Make / Model		MITSUBISHI FUSO 6D24T with turbo-charger / inter-cooler		MITSUBISHI FUSO 6D24T with turbo-charger / inter-cooler			
50		Rated Horsepower / r.p.m.	kW	165 / 2100	165 / 2100				
51		Maximum Torque / r.p.m.	N-m	980 / 1400	980 / 1400				
		Number of Cylinder		6	6				
52		Piston Displacement	cc	11940	11940				
		Alternator output	Amp	50	50				
	Fuel Tank Capacity	Liter	600	600					
55	Transmission	Type		Power - shift		Power - shift			
57	Operating Pressure	Stage	Fwd. / Rvs.	4 - 4	4 - 4				
		For Attachments	MPa(psi)	20.6	20.6				

Note : *Computed values

Dimensions

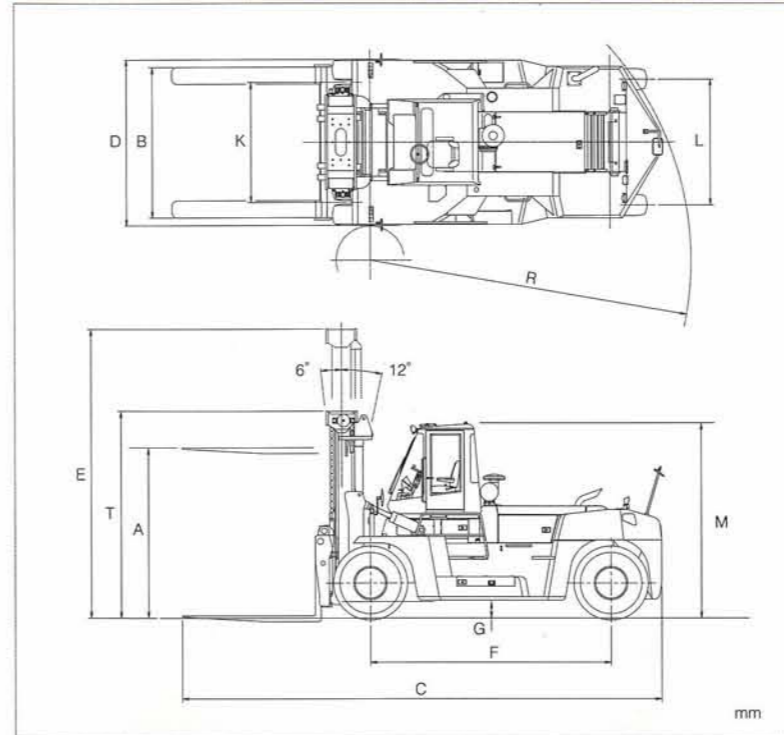

Mast Model	Capacity		Max. Fork Height	Overall Mast Height (lowered)		Overall Mast Height (raised)		Tilt Angle	Service Weight	
	FD250-3	FD300-3		FD250-3	FD300-3	FD250-3	FD300-3		FD250-3	FD300-3
	kg	kg	mm	mm	mm	mm	mm	degree	kg	kg
VM300	25000	30500	3000	3750	3750	5250	5250	6 / 12	34150	43440
VM350	25000	30500	3500	4000	4000	5750	5750	6 / 12	34350	43690
VM400	25000	30500	4000	4250	4250	6250	6250	6 / 12	34560	43940
VM450	25000	30500	4500	4500	4500	6750	6750	6 / 12	35050	44600
VM500	25000	30500	5000	4750	4750	7250	7250	6 / 12	35250	44860
VM550	24000	30500	5500	5000	5000	7750	7750	6 / 12	35460	45110
VM600	20000	30500	6000	5250	5250	8250	8250	6 / 12	35650	45360

Standard Equipment and Accessories

Equipment

- Automatic 4-speed powershift transmission
- Bonnet gas dumper with locking stay
- Brake cooling oil level view gauge
- Cartridge type filters; engine fuel, engine oil, mission oil & hydraulic oil
- Coolant reservoir tank
- Cyclopack type double element air cleaner
- Delux suspension seat
- Drawbar device in counter weight
- Electrically-controlled parking brake
- Engine oil dipstick
- Fork positioner(manual type)
- Front dual drive wheels
- Full hydrostatic power steering
- Heavy duty pneumatic tires
- Hydraulic oil level view gauge
- Large capacity fuel tank(600 liters)
- Load check valve
- Steel cabin with air-conditioner
- Tilt adjustable steering column
- Tilt cylinder lock valve
- Transmission oil dipstick
- Wet disc brake
- Wide view 2-stage mast
- 2440mm length forks

Accessories

- Buck-up buzzer
- Deluxe floor mat
- Electric horn
- Front combination lights turn signal & clearance
- Head lights
- Operator tool kit
- Rear combination lights, turn signal, tail, stop, back-up
- Rear reflectors
- Rear under-view mirror
- Room mirror
- Side view mirrors
- Turn signal lights(front)
- Working lights(front, rear)

Switch & Controls

- Automatic transmission mode select switch power mode & economy mode
- Electrically-controlled direction change lever inc. neutral safety lock device
- Electrically-controlled parking brake switch
- Lift lever
- Lighting switch
- Speed change hold switch (1st fixed / 2nd fixed / automatic speed shift)
- Starter switch inc. pre-heating & main switch
- Tilt lever
- Turn signal switch

Instruments

- Air cleaner clogging warning indicator
- Brake oil pressure warning indicator
- Brake oil temperature warning light
- Charge indicator
- Engine diagnosis monitor lamps
- Engine oil pressure warning indicator inc. engine oil filter clogging warning
- Engine pre-heating lamp
- Engine thermometer
- Fuel meter
- Hi-beam indicator(head lights)
- Hourmeter
- Parking brake indicator
- Speedometer
- Transmission oil temperature warning indicator
- Turn signal indicator
- Working light indicator

Optional Equipment and Accessories

Equipment

- Alternative fork length
- Alternative mast height
- Central greasing system
- Delux suspension seat with seat belt
- Detachable Ram / Fork attachment
- Fork positioner(hydraulic cylinder type)
- Fork positioner(hydraulic motor type)
- Fork positioner(hyd. cylinder) with side shifter
- Fork positioner(hyd. motor) with side shifter

- Heater & defroster
- Large capacity alternator
- Large capacity battery
- Load weight indicator
- Overhead guard type cab. with wide rubber floor mat
- Ram attachment
- Side shifter
- Split ram attachment

Accessories

- Custom paint-works
- Fire extinguisher
- Rotating warning yellow light(beacon)

Others on request

Load charts

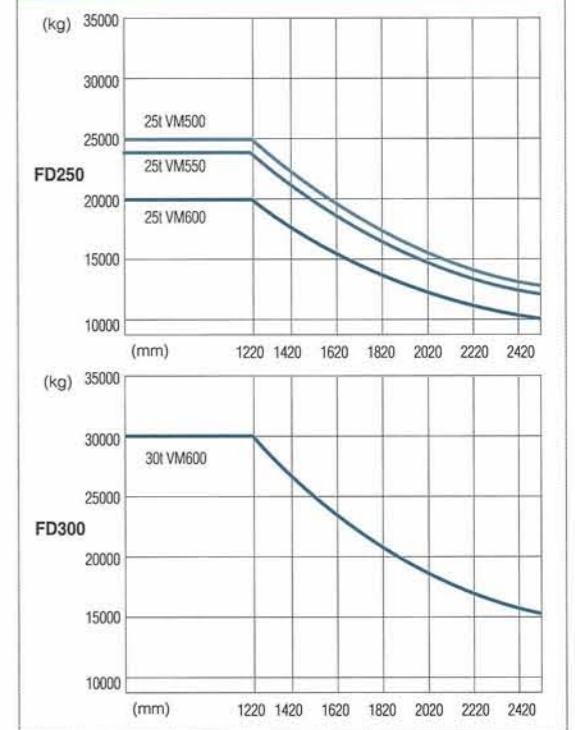



- TCM retains the right to change these products and specifications without incurring any obligation relating to such changes.
- These products and specifications are subject to change without notice.
- Photos and illustrations may or may not include optional equipment and accessories.
- Features and specifications may vary depending on markets.

Manufactured by

TCM

TCM CORPORATION

1-15-5 Nishi-Shimbashi, Minato-ku,
Tokyo 105-0003 Japan

TEL: +81 3 3591 8176

FAX: +81 3 3591 8152

www.tcmglobal.net

Distributed by