

TCM

by **UNI CARRIERS**

FTB Series

3-Wheel Cushion Tire

36 & 48 Volt AC Powered

3,000 lbs. Capacity

3,500 lbs. Capacity

4,000 lbs. Capacity



TCM

by **UNICARRIERS**[®]

Two years. Unlimited hours. It's more than just the best standard, limited warranty in the business*. It's also a reflection of the advanced engineering and workmanship that go into our forklifts—and the result of more than half a century of bringing innovation and excellence to forklift manufacturing.



Up Your UpTime

Reliability is key and that's no mistake. Design, engineering and relentless testing are part of our DNA. The result is what we expect and what you demand.



Comfort Zone

Work comes first, but there are amenities that make the experience more pleasurable. And happy drivers are statistically more productive.



Power & Performance

Our 100% AC motors and controller system and intuitive designs allow you to move in a way that makes sense. The resulting productivity saves you time, money and driver mishaps.



Sweet Savings

Our low cost of ownership is something you can take to the bank. We take our commitment to delivering value seriously because we know you do.

The extraordinary maneuverability of a compact 3-wheel truck to negotiate tight turns and narrow aisles...the reliable 100% AC motors that eliminate emissions without sacrificing torque and power... the legendary reliability and uptime performance that define our brand — it all comes together in FTB Series forklifts for the ultimate in versatility, economy and productivity.

FTB Series forklifts are designed and engineered with performance features only available from UniCarriers. As you look through these pages, check for the symbols below for features exclusive to the FTB Series, or those that provide a proven performance advantage far above any you'll find on competitive equipment.



The FTB Series brings greater performance and value to:

- Food products companies
- Warehousing operations
- Manufacturing

...or any business that's looking for a more maneuverable forklift, greater productivity in their operations and ready to make a commitment to zero emissions.



Play It Safe

Your employees' well-being is an imperative. Standard protection features mean greater confidence in the workplace.



Control Freak

Our advanced features give you control to promote operator security, manage your productivity, contain costs, or do all these things at once.



Make It Yours

Choose from a variety of options to customize your ride. If you don't see what you need, contact your authorized TCM by UniCarriers dealer for help.



To learn more, and find a dealer near you, visit UniCarriersAmericas.com



Up Your UpTime

FTB Series forklifts incorporate a full range of advanced technologies to keep your operation up, running and productive. As a result, our trucks use fewer parts, require less scheduled maintenance, extend battery life and our ultra-reliable AC drive and hydraulic motors provide greater efficiency — delivering more consistent power and performance throughout each shift.



Stay Cool

Built-in thermal sensors alert the driver in the event of motor overheating, and automatically lower travel and lift operations to protect the drive motors, pump motor and controller system. The information is locked into the truck's service history to assist the technician.



Easily check brake fluid levels on the front dash.



Quickly access dipstick and hydraulic fluid under the hood.

AC Motor/Controller

Our **100% AC motors and controller system** are harmonized by our engineers, setting the standard for reliability and creating a finely tuned and synergized system that boosts operating performance and efficiency even higher.



Dependable Drive Units

Dependable performance is achieved through the synching of our **brushless AC induction motors** with a simple, yet effective, transmission design. The result is less complexity, fewer parts and reduced maintenance.

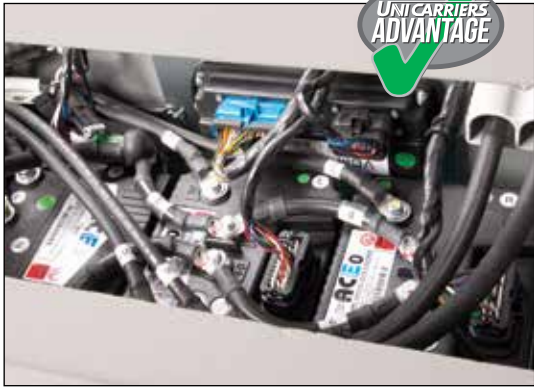

Sealed Controller

The controllers are located in the rear of the truck — between the counterweight and the battery box— and protected by two removable panels. Their **IP65 rating** means they're housed within an enclosed and waterproof structure to protect against water and dust.

1 Switchback regeneration

2 Foot brake regeneration

3 Accelerator-off regeneration

4 Controlled rollback regeneration

5 Lifting/lowering regeneration

Battery Regeneration

To get more power and performance from every charge, the FTB Series uses five different sources of battery regeneration: switchback, foot brake, deceleration, controlled rollback and lifting/lowering.



Conserve Your Energy

With the standard **Auto Power Off** feature, power is cut off to the truck if it remains idle for a pre-set period of time. (Comes factory programmed at 15-minutes, but can be adjusted from 1–60 minutes.)



On-Demand Power Steering

With load sensing power steering, a single motor powers both steering and hydraulics — **reducing the number of parts and energy consumption.**



Comfort Zone

UniCarriers incorporates proven, ergonomic designs throughout the FTB Series forklifts to optimize the comfort and visibility of your operators — while it maximizes the performance of your entire operation.



Sit & Relax

A comfortable **full-suspension seat** absorbs shocks for a smoother, more comfortable ride — and features weight and back angle adjustments, hip restraints and a retractable seatbelt.



We've Thought Of Everything

Switching between the brake and accelerator is easier, more fluid and safer, thanks to our **heel-to-toe** concept that ensures the pedals are at the same height when released.

Visibly Better

The FTB is designed to provide a commanding view of the surrounding environment and clear sightlines to the fork tips by virtue of the low-front dash panel.





A Step Up In Operator Comfort

Designed with a wide step for easy entry into the spacious cabin that boasts leg and foot room that are among the industry's largest. It also offers an amazing head clearance for such a compact forklift.



Battery Plug

Unlike competitive trucks, we've placed the battery plug under the hood and away from driver's legs.



Hands-On Operation

A standard small diameter, tilt steering wheel can be paired with an optional spinner knob for extra operator control. Further customize driver preference by selecting an optional steering column that provides an extra 2" of height.



Performance At Your Fingertips

With our optional fingertip controls, you barely have to move your fingers to command control over travel direction, lift, auxiliary functions and horn.

Integrated into a comfortable armrest, it provides operators with the ultimate in ergonomic efficiency. Choose between a combined or separate lift & tilt lever design.

Perfectly Placed

Ergonomically placed parking brake, deck-mounted hydraulic controls and automotive-style forward/reverse directional controls, lights and turn signals put operator comfort and productivity all within easy reach.



Power & Performance

The FTB Series matches turn-on-a-dime maneuverability with power, torque, speed and control to deliver optimal performance and productivity for each application and in just about every environment.

Smooth Moves

FTB Series trucks are powered by two separate AC drive motors that are individually controlled by our AC Tech Controller. During tight turns, the inner wheel counter rotates so **the truck can turn within its own footprint** for unsurpassed maneuverability.

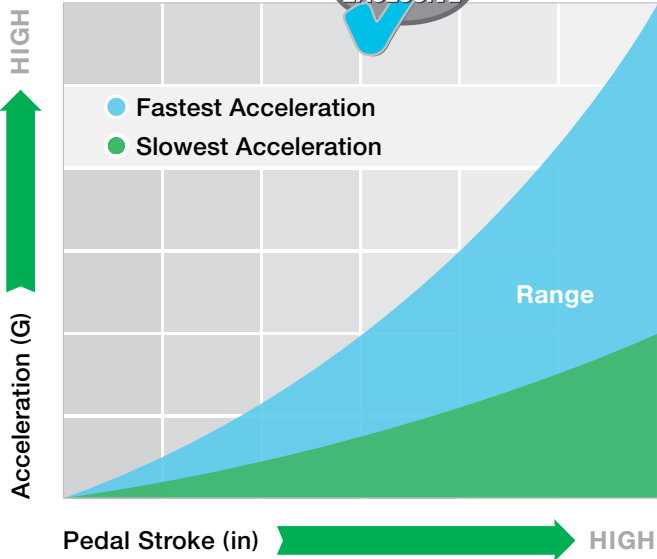
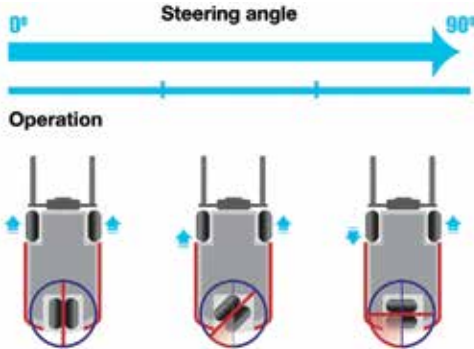

The Right Response For The Job

Our unique Flex Logic control lets you adjust the sensitivity of the forklift's acceleration to match the operational requirements of the job and/or the skill level of the operators. Set for quick response and **fast acceleration for longer runs** and more open operating environments — or set for **slower acceleration in higher traffic areas** or wherever precision handling is desired. Flex Logic control works in any of the truck's power mode settings — and is only available from TCM by UniCarriers.

Peak Performance

Our top-end performance numbers are impressive, and so is the capability of FTB Series forklifts to deliver quicker acceleration and higher speeds when you need to maximize work cycles and productivity.

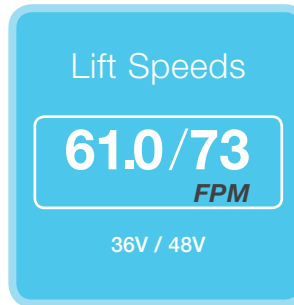

Based on FTB35 model

Customized Performance

Comes with three factory programmed performance settings— and allows you to create customized settings finely tuned to the capabilities of your operators and the goals of your business. (Performance specifications for each setting available on page 19)

- E Economy Mode**
Minimizes battery draw for extended operating time without sacrificing a lot of performance.
- P Performance Mode**
A blend of energy efficiency and the performance you need for normal operations.
- H High Performance Mode**
Delivers maximum travel speed and lifting performance.
- M Manual Mode**
Customize performance to meet the needs of the job and the skill level of the operator.

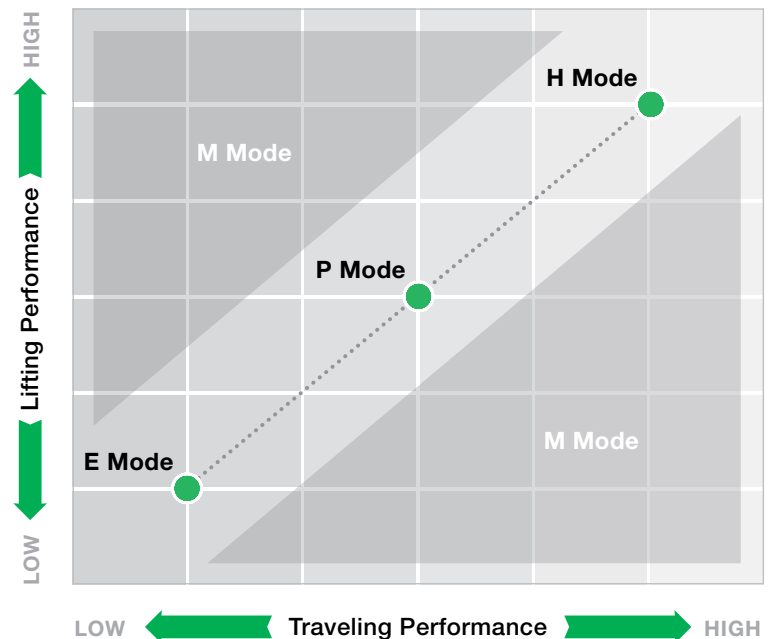



Sweet Savings

At UniCarriers, we're always looking for opportunities to lower the cost of owning our trucks — and we've found them. Take a look at just a few of the ways we've designed the FTB Series forklifts to be faster, easier and more economical to operate and maintain.



More Power To You

Advanced regenerative technology reclaims power from five different operations — lowering power consumption, extending operating hours, reducing component wear and keeping your equipment out of the charging bay.



Quick Check

A gas spring assist with locking mechanism provides easy access for the required daily battery and hydraulic fluid checks.



On-Board Diagnostics

On-board diagnostics and truck service history are available through the meter panel for **quick troubleshooting** — resulting in less downtime and increased productivity. No tablet, laptop or handset tool is required.



by UNI CARRIERS®

Our Overhead Guard Reduces Your Overhead

Our modular, 4-piece overhead guard takes less time to make needed replacements versus competitors' single-piece, welded-on guards. That cuts downtime and costs.

The Brake You Need

The reliable 6-disc wet-type brake system is fully enclosed within the drive unit. This design helps eliminate dirt and debris entry to **prevent premature brake wear**, keeps oil cleaner, extends brake life, lengthens service intervals and lowers your costs.

Quick Fix

The modular design of the powertrain speeds and simplifies maintenance. The **gear box and motor can be removed, serviced and replaced as a unit** – without removing the mast for service.

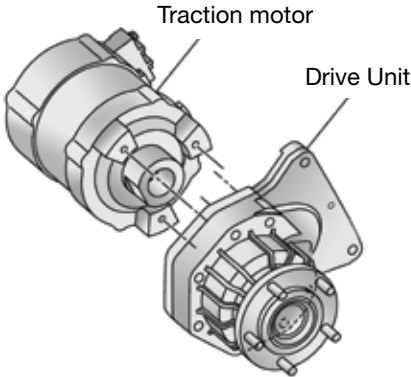

1,200
2,400

Low Maintenance

Extended major service intervals of 1,200 and 2,400 hours mean more uptime with less time, effort and money expended on maintenance.



Play It Safe

You have a commitment to workplace and operator security. So do we. That's why you'll find some of the most sophisticated and reliable control systems on our FTB Series forklifts — all designed to protect your employees and your business.



Extra Protection

Our standard back-up alarm provides notice to pedestrians and other drivers in the surrounding environment. For applications with varying noise levels, choose an optional self-adjusting alarm that responds based on the environment's ambient volume level.

Reverse driving actuates optional blue spotlight to illuminate the floor, for advanced visual warning.



Always In Control

Our **Controlled Rollback** system uses regenerative braking to automatically maintain a slow, consistent speed on a ramp or incline when the accelerator pedal is released.



Custom Performance & Secure Access

Up to five different, customized performance profile settings can be quickly and easily entered through the meter panel. PIN codes help ensure access is only available to qualified operators and the settings are matched to the abilities of each driver.

TCM

by UNICARRIERS®

Highly Sophisticated Operator Presence System

When the operator leaves the seat, it automatically locks the mast's lift and tilt, shifts the transmission into neutral and alerts the driver to set the parking brake. Upon returning to the seat, it also reminds the driver to fasten the seatbelt.



Seeing Is Believing

Our optional OptiView® mast is designed with cylinders behind the mast rails — resulting in fewer visual obstructions, clearer sightlines to the fork tips and greater forward visibility.



Control Freak

Whether it's restricting access to the forklift, regulating travel speed or limiting operating costs, the FTB Series provides you with the control you need to manage your operation easily, effectively and completely.

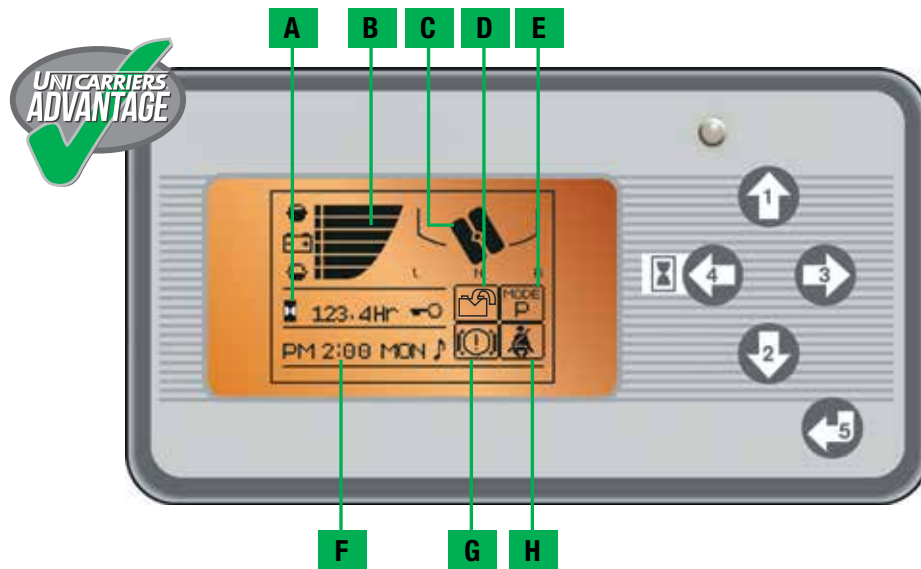

The Ultimate In Control

The meter panel is your portal to a vast array of performance and control features. No tablet, laptop or other handset tool is required to:

- Control access through individual PIN codes
- Customize performance settings to individual operators
- Set speed/acceleration parameters
- Select the optimal power mode

...and access to a wealth of vital information to manage your operation including: error codes; operating hours; service history; truck status; and diagnostics.

Emergency Disconnect

The emergency disconnect button is strategically positioned for a quick, intuitive action.



Our multi-dash function LCD display provides operators with an at-a-glance view of critical functions:

- A** 4-Mode Hour Meter or Energy Consumption Indicator
- B** Battery Capacity Indicator
- C** Speed/Steer Wheel Indicator
- D** Regeneration Indicator
- E** Performance Mode
- F** Clock/Acceleration Level Adjustment
- G** Parking Brake Warning
- H** Seat Belt Warning

TCM

by UNICARRIERS.



Parking Brake/Alarm

A warning buzzer alerts the driver if he leaves the seat without setting the parking brake.

Speed Synched

With our exclusive Flex Logic control, the **acceleration rate varies based on the speed at which the pedal is pressed** — fast acceleration for longer runs...or slower acceleration for easier maneuvering in higher traffic areas, tight spaces and making final approaches. See page 8 for details.





Make It Yours

Unlike competitive brands, the FTB Series comes standard with the most essential and popular features and accessories. In addition, we offer a complete menu of additional options that allow you to customize your forklift to fit your specific workplace environment, operations and business objectives. On these pages, you'll find available options that are both innovative and economical — but it's only a portion of what we offer. So if you don't see what you're looking for here, call your TCM by UniCarriers dealer for more options.



• Fire Extinguisher



• Steering Wheel With Spinner Knob

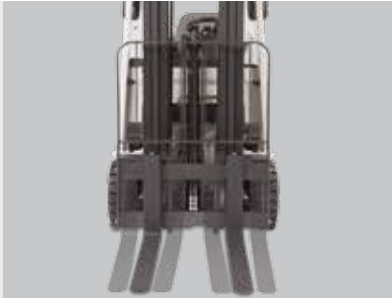

Side-Shifting Fork Positioner

Hydraulic fork adjustment eliminates the need to manually move forks for different pallet types.



Freezer Package

For operating in environments as low as -31°F (-35°C) – includes special hydraulic oil.



Strobe Light

Available in a variety of colors.



Auto Fork Leveling

Conveniently located on the hydraulic lever, the thumb-activated button automatically tilts the mast forward, bringing forks to 90° for easier load placement and retrieval.



Battery Rollers

Simplify battery change-outs. Roller design includes a side panel that's easily removable for quick battery access.



OptiView® Mast

Our exclusive 3-stage design provides wider sightlines and improved load handling visibility.



Higher Steering Wheel

The stationary design provides an extra 2.2" of steering wheel height for enhanced operator comfort.



Lower Overhead Guard

Designed with a 78.6" height for more confined, height-restricted areas. Other heights also available.



Fingertip Controls

Fingertip controls integrated into an adjustable armrest for smoother, more precise control. Can be ordered with our exclusive single lift/tilt joystick*

*Restrictions on combining this with other optional features may apply. Consult your authorized TCM by UniCarriers dealer for details.

Option Availability

● Standard

○ Optional

VEHICLE MANAGEMENT

AC TECH motor controller system	●
Interactive LCD meter panel with adjustable performance settings	●
Operator security PIN access	●
3 preset performance modes (economy, normal, high)	●
1 manual (custom) performance mode	●
On-board diagnostics, self test and coded service history	●
Low battery lift interrupt system	●
Controlled rollback	●

BATTERY/ELECTRICAL

36 Volt system	●
48 Volt system	○
Battery compartment rollers	○
Fully enclosed 6-disc wet type brakes	●

BRAKE

Hand applied parking brake with warning buzzer	●
5-mode regenerative braking	●

MAST

Seat actuated auto-mast lock system	●
OptiView® three-stage mast	○

HYDRAULIC SYSTEM

Deck-mounted control levers	●
Electronic fingertip control levers (separate lift and tilt or single levers)	○
Auto-fork leveling	○
Accumulator	○
Extra tilt	○

OPERATOR CONVENIENCES

Full suspension seat with weight adjustment	●
OHG-mounted headlights and turn signals	●
Rearview mirrors	●
Rear combination light package (turn, stop, back-up)	●
Rear work light	●
Strobe lights	○
Steering wheel with spinner knob	○
Magnetic convenience box	○
Low overhead guard (78.6")	○
Solid pneumatic tires	○

PROTECTION/SECURITY

Operator Presence System with return-to-neutral & auto mast lock	●
Fire extinguisher	○
Back-up warning alarm	●
Self-adjusting back up alarm	○

Some options may require additional lead time. Consult your authorized TCM by UniCarriers dealer for details. FTB models conform to UL583 Type E.

Specifications

SHORT MODEL CODE	LOAD CAPACITY lb (kg)	WHEELBASE in (mm)	OVERALL WIDTH in (mm)	MIN OUTSIDE TURNING RADIUS in (mm)	OVERHEAD GUARD HEIGHT in (mm)
FTB15-A1	3000 (1500)	51.2 (1300)	43.5 (1105)	60 (1525)	83.4 (2120)
FTB18-A1	3500 (1750)	51.2 (1300)	43.5 (1105)	60 (1525)	83.4 (2120)
FTB20	4000 (2000)	55.5 (1410)	43.5 (1105)	64.4 (1635)	83.4 (2120)

Preset Performance Specifications

SETTING	FTB15-A1		FTB18-A1		FTB20		
	36 V	48 V	36 V	48 V	36 V	48 V	
HIGH							
Travel Speed	Empty mph (kmh)	9.0 (14.5)	10.0 (16.0)	9.0 (14.5)	10.0 (16.0)	9.0 (14.5)	10.0 (16.0)
	Loaded mph (kmh)	9.0 (14.5)	10.0 (16.0)	9.0 (14.5)	10.0 (16.0)	9.0 (14.5)	10.0 (16.0)
Lift Speed	Empty fpm (mm/s)	101 (515)	118 (600)	101 (515)	118 (600)	101 (515)	118 (600)
	Loaded fpm (mm/s)	67 (340)	79 (400)	61 (310)	73 (370)	53 (270)	63 (320)
NORMAL							
Travel Speed	Empty mph (kmh)	8.8 (14.0)	9.7 (15.5)	8.8 (14.0)	9.7 (15.5)	8.8 (14.0)	9.7 (15.5)
	Loaded mph (kmh)	8.8 (14.0)	9.7 (15.5)	8.8 (14.0)	9.7 (15.5)	8.8 (14.0)	9.7 (15.5)
Lift Speed	Empty fpm (mm/s)	100 (510)	108 (550)	100 (510)	108 (550)	100 (510)	108 (550)
	Loaded fpm (mm/s)	62 (315)	71 (360)	57 (290)	63 (320)	51 (260)	58 (295)
ECONOMY							
Travel Speed	Empty mph (kmh)	8.1 (13.0)	8.8 (14.0)	8.1 (13.0)	8.8 (14.0)	8.1 (13.0)	8.8 (14.0)
	Loaded mph (kmh)	8.1 (13.0)	8.8 (14.0)	8.1 (13.0)	8.8 (14.0)	8.1 (13.0)	8.8 (14.0)
Lift Speed	Empty fpm (mm/s)	91 (460)	98 (500)	91 (460)	98 (500)	91 (460)	98 (500)
	Loaded fpm (mm/s)	54 (275)	59 (300)	51 (260)	51 (260)	46 (235)	47 (240)



Power, performance and reliability...all backed by the best standard limited warranty in the business!*

- 2 Years
- Unlimited Hours

* Contact Unicarriers Americas for specific details, limitations, and exclusions.

Built Like No Others.
Backed Like Nothing Else.



Quality, performance, reliability and efficiency — we believe that the same attributes that make a great forklift are also essential elements of an exceptional company. As a result we've built an organization that overlooks no detail in manufacturing material handling equipment that delivers the highest level of **performance and value** — and that stands behind our products with comprehensive service and support.

Our products are designed to produce maximum productivity without compromising operator safety. **They're built to exacting standards to maximize uptime.** They're scrupulously tested to ensure strict tolerances are met — and offered by a network of highly skilled, highly professional dealerships committed to customer satisfaction.

And when it comes to the environment, we put the same passion and energy into creating an effective sustainability initiative as we put into engineering our products.

At UniCarriers, our mission is to **continuously move performance standards upward** — and to provide the support you need to **move your business forward.**

SB-FTB 12-2014
Printed in U.S.A.



UniCarriers® is a registered trademark of UniCarriers Corporation. OptiView® is a registered trademark of UniCarriers Corporation. UniCarriers Americas Corporation reserves the right to make product changes relating to colors, equipment, specifications or available options without notice.

For more information, contact your TCM by UniCarriers representative.

UNI CARRIERS®

UniCarriers Americas Corporation

UniCarriersAmericas.com