

# Material Handling Solutions by Omega Lift



## MEGA Series



### STANDARD EQUIPMENT

#### Engine

- Perkins diesel engine
- Emissions compliant
- Glow Plugs

#### Transmission

- Power shift transmission—3 speeds forward / 3 reverse
- Electric column shifter with torque converter
- Transmission disconnect on park brake
- Transmission oil cooler

#### Axles/Brakes

- Planetary 4-wheel drive
- 3 steering modes (4-wheel, crab, 2-wheel)
- Enclosed, wet disc brakes
- Oscillating rear axle
- Limited slip differential (rear axle)
- Hydraulic powered brakes with accumulator
- Internal spring applied hydraulic release park brake (SAHR)

#### Operator Compartment

- Open FOPS
- Tilttable and telescopic steering column
- Low profile mechanical suspension seat with lumbar adjustment and retractable seat belt

- Grab handles and cab step
- 2 speed fan

#### Instrumentation

- Full gauge cluster including; fuel level, water temperature, engine oil pressure, AMP meter.
- Indicator lights including; low battery, low oil pressure, high water temperature, high transmission oil temperature, park brake

#### Mast/Carriage

- I-beam roller bearing mast
- Clear View design
- Premium mast chain
- Hardened chain pulleys
- Sealed, maintenance-free roller bearings
- Shaft Carriage
- Shaft Forks

#### Electrical

- 12V negative ground system
- Labeled fuses with holder
- 970 CCA battery
- 65 AMP alternator

#### Additional Features

- Solid steel frame construction
- Frame leveling
- Steel hydraulic and fuel tanks
- Lockable fuel, hydraulic, engine hood and battery compartment

- Front work lights
- Rear flashers
- 2-stage air cleaner
- Horn and back-up alarm
- Tie down provisions

### OPTIONAL EQUIPMENT

- Various engine options
- Block heater with extension cord
- Enclosed all-weather cab
- Air Conditioning
- AM/FM CD sound system
- Lighting package
- Mirror package
- Premium mechanical suspension seat
- Customizable mast, carriage and forks
- Mast side shift
- Fork positioning
- Light material bucket
- Grapple
- Fire suppression system
- External camera with LCD display
- Foam-filled tires
- Cold weather packages
- Tire Sealant
- Tire options
- 24V Electrical System
- Air intake pre-cleaner



1.905.857.6456 | [www.omegalift.net](http://www.omegalift.net)

# MEGA Series

3650 – 9100 kg load capacity

4,57 – 6,1 m lift height

The powerful **MEGA Series** covers many applications from lumber and steel to general heavy lifting, and can handle loads up to 9100 kg. Capable of extended load centers, it features a strong frame and mast design to handle extra heavy loads. The MEGA Series is the solution for unique and heavy loads.

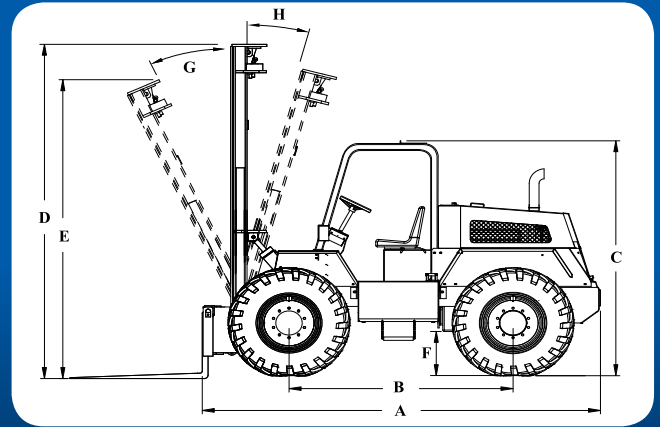

SPECIFICATION	Ref.	8MS	10MS	12MS	14MS	16MS	18MS	20MS	
Lift Capacity @ 610mm load centre (kg)		3650	4550	5450	6350	7300	8200	9100	
Overall length (without forks) (mm)	A	4267	4267	4546	4546	4915	5334	5334	
Overall width (mm)		2515							
Wheelbase (mm)	B	2311	2311	2565	2565	2921	2921	2921	
Height to top of overhead guard* (mm)	C	2845	2845	2845	2845	2845	2972	2972	
Closed height standard mast (mm)	D	3556	3556	3556	3556	3099	3251	3251	
Height standard full mast tilt (mm)	E	3226	3226	3226	3226	2845	2997	2997	
Ground clearance (mm)	F	381							
Maximum lift height (std. mast) (mm)		4572	4572	4572	4572	3658	3658	3658	
Outside turning radius (mm)		4445	4445	4699	4699	5486	6071	6071	
Drive		4-wheel drive							
Steering		4-wheel steer/2-wheel steer/ Crab Steer							
Mast clearance (mm)		292	292	292	292	292	267	267	
Mast tilt - forward	G	25°							
Mast tilt - rear	H	15°							
Mast side shift - optional		+/- 76 mm							
Travel speed unladen - forward		27 km/h							
Gradeability		40%							
Tire size		E2/L2A 15.5x25-12ply					E2/L2A 17.5x25-16ply		
Engine Manufacturer and model		Perkins 1104D-44T Turbo Diesel							
Cylinders		4 Cylinders							
Horsepower		74.5 kW (99 HP) @ 2400 rpm							
Transmission		Powershift—3 speed-forward / 3 speed reverse							
Shipping weight (kg)		9547	10065	10796	11975	12428	13971	14780	

\* including light beacon

Manufacturers specifications subject to change without notice

NOTE: The information herein is general in nature and is not intended for specific application purposes. Omega Lift reserves the right to make any changes in the specifications shown herein, and improvements, or discontinue manufacture at any time without notice or obligation. Units shown may be equipped with non-standard equipment. All machines are manufactured to meet or exceed ANSI/ITSDF B56.6 - 2005 Standards or Recommended Practices, where applicable. Printed in Canada. Reorder Code: MEGASS-NA-M-1-11

