

Material Handling Solutions by

# Omega Lift



**HERC Series**

11350 -  
31750 kg cap.



Omega Lift has been designing and manufacturing all-terrain lift trucks for a wide range of material handling applications for over 30 years enabling us to be at the forefront of lift truck design.



**ANY JOB.  
ANYTIME.  
ANYWHERE.**



# HERC Series

**11350 – 31750 kg load capacity**  
**3,65 m lift height**

This full time 4-wheel drive forklift combines heavy lifting capabilities with the versatility to work in rough terrains. The HERC Series is available in capacities up to 31750 kg @ 1200 mm load centre, and is ideal for over-dimensional loads. The HERC sits on a solid steel frame, is driven by a 6-cylinder diesel with 4-speed powershift transmission which means it can move bulky, heavy loads in applications where many others just can't operate. ANY JOB. ANYTIME. ANYWHERE.



SPECIFICATION	Ref.	2425-24	2430-24	2435-24	2435-36	2435-48	2440-48	2450-48	2470-48
Lift Capacity (kg)		11350	13600	15900	15900	15900	18000	22700	31750
Load Centre (mm)		600	600	600	900	1200	1200	1200	1200
Overall length (without forks) (mm)	A	5588	5588	6248	6248	6731	6731	8077	8077
Overall width (mm)		2540	2540	3048	3048	3048	3048	3048	3404
Wheelbase (mm)	B	3556	3556	3810	3810	3810	4064	5080	5080
Height to top of overhead guard* (mm)	C	3099	3099	3099	3099	3099	3099	3429	3556
Closed height standard mast (mm)	D	3658	3658	3658	3658	3658	3658	3658	3658
Height standard full mast tilt (mm)	E	3429	3429	3429	3429	3429	3429	3480	4013
Ground clearance (mm)	F	356	356	430	430	430	430	356	356
Standard lift height (mm)		3658	3658	3658	3658	3658	3658	3658	3658
Outside turning radius (mm)		7214	7214	7569	11074	11074	11328	11582	12090
Drive		4-wheel drive							
Steering		2-wheel steer							
Mast clearance (mm)		279						356	
Mast tilt - forward	G	15°							
Mast tilt - rear	H	13°							
Carriage side shift - standard		+/- 6"					+/- 10"		
Travel speed unladen - forward		24 km/h							
Gradeability		40%							
Tire size		1800-25 32 PLY, 1200-20 20 PLY			12.00R24			14.00R24	16.00R25
Engine Manufacturer and model		Perkins 1106D-E66TA Turbo Diesel							
Cylinders		6 Cylinders							
Horsepower		130 kW (174 HP) @ 2400 rpm						168 kW (225 HP) @ 2400 rpm	
Transmission		Powershift—4 speed-forward / 4 speed reverse							
Shipping weight (kg)		17950	20186	22573	23564	24455	29227	37536	43136

\*Including Light Beacon  
Manufacturers specifications subject to change without notice

NOTE: The information herein is general in nature and is not intended for specific application purposes. Omega Lift reserves the right to make any changes in the specifications shown herein, and improvements, or discontinue manufacture at any time without notice or obligation. Units shown may be equipped with non-standard equipment. All machines are manufactured to meet or exceed ANSI/ITSDF B56.6 - 2005 Standards or Recommended Practices, where applicable. Printed in Canada.





HYDRAULIC TEST PORTS & HOSE GUARDS SENSIBLY LOCATED



ALL STEEL, SPACIOUS CAB INTERIOR



FOPS CANOPY WITH RAIN PROTECTION STANDARD EQUIPMENT



ERGONOMIC, PROPORTIONAL CONTROLS



ACCESSIBILITY UNDER THE HOOD



HEAVY DUTY MAST & CARRIAGE FABRICATED USING T1 / QT100 STEEL



40% GRADE-ABILITY FOR SEVERE OFF-ROAD ABILITY



BUILT IN SAFETY THRU ANSI B56.6 CERTIFICATION



EXCELLENT MAST VISIBILITY



FORK POSITIONER & SIDE-SHIFT STANDARD EQUIPMENT



FULL TIME 4-WHEEL DRIVE FOR REAL LIFE APPLICATIONS



ENTRY/EXIT W/ 3-POINTS OF CONTACT



ON-BOARD STORAGE



OSCILLATING REAR AXLE & WET DISC BRAKES

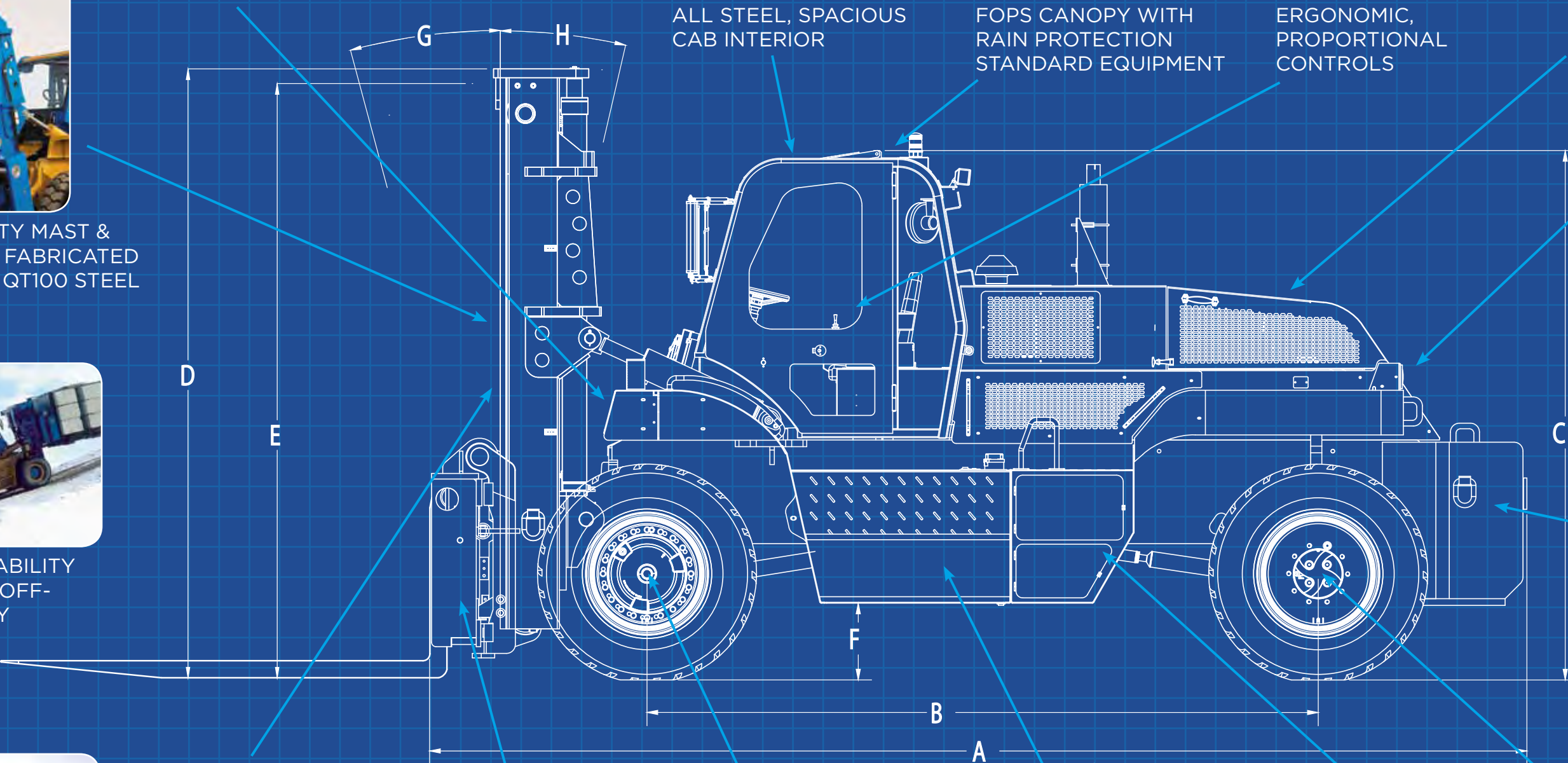

BACK-UP CAMERA STANDARD EQUIPMENT



REMOVEABLE COUNTER-WEIGHT

## STANDARD EQUIPMENT

### Engine

- Perkins turbo charged diesel engine
- Outboard muffler with aluminum piping; improved visibility and emissions control
- Emissions compliant
- 2 stage dual air cleaner with turbo pre-cleaner
- Electronic engine diagnostics
- Built in shut-down system for engine and transmission
- High capacity cooling system for dependable operation in all environments
- Glow Plugs

### Transmission

- Powershift transmission with automatic shifting control and inching capabilities 4 speed forward / 4 speed reverse
- Electric column shifter with torque converter
- Transmission disconnect on park brake
- Transmission oil cooler

### Axles/Brakes

- Planetary 4-wheel drive
- 2 wheel steer
- Rigid front drive axle
- Enclosed wet disk brakes
- Rear oscillating drive/steer axle
- Hydraulic powered brakes with accumulator
- Internal spring applied hydraulic release park brake (SAHR)

### Operator Compartment

- Open FOPS
- Tilt-able and telescopic steering column
- Low profile mechanical suspension seat with lumbar adjustment and retractable seat belt
- Grab handles and cab step
- 2 speed fan

### Instrumentation

- Full gauge cluster including; fuel level, water temperature, engine oil pressure, volt meter.
- Indicator lights including; low battery, low oil pressure, high water temperature, high transmission oil temperature, park brake

### Mast/Carriage

- I-beam roller mast
- Clear view design
- Premium mast chain
- Hardened chain pulleys
- Sealed, maintenance-free roller bearings
- Shaft carriage
- Shaft forks

### Electrical

- 12V negative ground electrical system
- Labeled fuses with holder
- 970 CCA battery
- 65 AMP alternator

### Additional Features

- Solid steel frame construction
- Steel hydraulic and fuel tanks
- Hydraulic fork positioning and hydraulic carriage side shift
- Load sensing open circuit priority type hydraulic system
- External camera with LCD display
- Lockable fuel, hydraulic, engine hood and battery compartment
- Front work lights
- Rear flashers
- 2-stage air cleaner
- Horn and back-up alarm
- Tie down provisions

## OPTIONAL EQUIPMENT

- Various engine options
- Block heater with extension cord
- Enclosed all-weather cab
- Cold weather package
- Air conditioning
- AM/FM CD sound system
- Lighting package
- Mirror package
- Premium mechanical suspension seat
- Premium air seat
- Customizable mast, carriage and forks
- Light material bucket
- Grapple, 1 or 2 function
- Fire suppression system
- Foam-filled tires
- Tire sealant
- Tire options
- 24V Electrical system
- Air intake pre-cleaner
- DS-Rating / UL558 Certified
- Lifting Provisions

## Authorized Omega Lift Dealer

Printed in Canada. Reorder Code: HERCSB-M-10-11

## A MACHINE FOR EVERY APPLICATION



### Omega Lift

87 Simpson Rd.  
Bolton, Ontario  
Canada L7E 3R6

