



# Material Handling Solutions by **Omega Lift**



## ALPHA Series



### STANDARD EQUIPMENT

#### Engine

- Perkins diesel engine
- EPA compliant
- Glow Plugs

#### Transmission

- Power shift transmission—  
3 speeds forward / 3 reverse
- Electric column shifter with  
torque converter
- Transmission disconnect on  
park brake
- Transmission oil cooler

#### Axles/Brakes

- Planetary 4-wheel drive
- 3 steering modes: 4WS/crab/2WS
- 4-wheel enclosed, wet disc brakes
- Oscillating rear axle
- Hydraulic powered brakes  
with accumulator
- Internal spring-applied hydraulic  
release park brake (SAHR)

#### Operator Compartment

- Open FOPS
- Tiltable and telescopic  
steering column
- Low profile mechanical suspension

- seat with lumbar adjustment  
and retractable seat belt
- Grab handles and cab step
- Roof glass

#### Instrumentation

- Full gauge cluster including; fuel  
level, water temperature, engine  
oil pressure, AMP meter.
- Indicator lights including; low  
battery, low oil pressure, high  
water temperature, high  
transmission oil temperature,  
glow plugs, park brake

#### Mast/Carriage

- I-beam roller mast
- Clear View design
- Premium mast chain
- Hardened chain pulleys
- Sealed, maintenance-free  
roller bearings
- Shaft Carriage
- Shaft Forks

#### Electrical

- 12 V negative ground system
- Labeled fuses with holder
- 970 CCA battery
- 65 AMP alternator

#### Additional Features

- Frame leveling
- Solid steel frame
- Steel hydraulic and fuel tanks
- Lockable fuel, hydraulic, engine  
hood and battery compartment
- Front work lights
- Rear flashers
- 2-stage air cleaner
- Horn and back-up alarm

#### OPTIONAL EQUIPMENT

- Enclosed all-weather cab
- Block heater with extension cord
- Air Conditioning
- AM/FM CD Sound System
- Lighting package
- Mirror package
- Washer system
- Foam-filled tires
- Customizable mast, carriage and forks
- Anti-theft device
- Fork Positioning
- Side shift



1.905.857.6456 | [www.omegalift.net](http://www.omegalift.net)

# ALPHA Series

## 2750 kg load capacity

The muscular **ALPHA Series** is a solid rough terrain machine that provides the robust build quality of the larger Omega Lift models in a compact, efficient package. The exceptional maneuverability of this 4-wheel drive, 4-wheel steer machine ensures that it is perfectly suited for applications where space is limited.

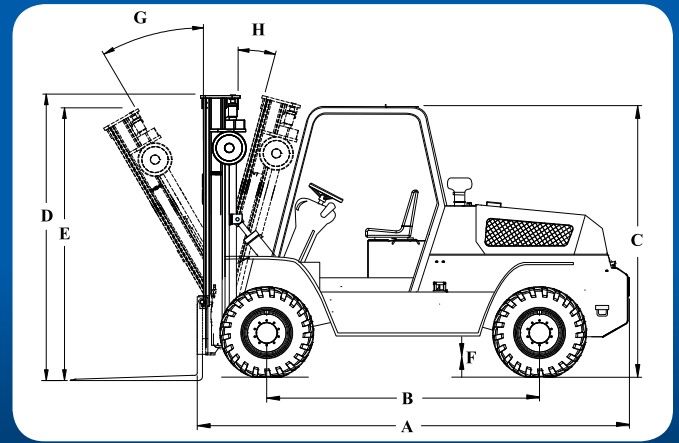

SPECIFICATION	Ref.	446-AS
<b>Lift Capacity @ 610mm load centre (kg)</b>		2750
<b>Overall length (without forks) (mm)</b>	A	3632
<b>Overall width (mm)</b>		1632
<b>Wheelbase (mm)</b>	B	2184
<b>Height to top of canopy (mm)</b>	C	2287
<b>Closed height standard mast (mm)</b>	D	2540
<b>Maximum lift height (std. mast) (mm)</b>		3048
<b>Height standard full mast tilt (mm)</b>	E	2496
<b>Outside turning radius (mm)</b>		3002
<b>Ground clearance (mm)</b>	F	356
<b>Mast clearance (mm)</b>		279
<b>Mast tilt - forward</b>	G	25°
<b>Mast tilt - rear</b>	H	15°
<b>Travel speed unladen - forward</b>		21 km/h
<b>Gradeability</b>		40%
<b>Steering</b>		4WS/Crab/2WS
<b>Drive</b>		4-wheel drive
<b>Tire size - front</b>		825-15 14G TT
<b>Tire size - rear</b>		825-15 14G TT
<b>Engine Manufacturer and model</b>		Perkins 1104 Natural Diesel
<b>Cylinders</b>		4 Cylinders
<b>Horsepower</b>		64 kW (86 HP) @ 2400 rpm
<b>Transmission</b>		Powershift—3 speed forward / 3 reverse
<b>Shipping weight (kg)</b>		5643

Manufacturers specifications subject to change without notice

NOTE: The information herein is general in nature and is not intended for specific application purposes. Omega Lift reserves the right to make any changes in the specifications shown herein, and improvements, or discontinue manufacture at any time without notice or obligation. Units shown may be equipped with non-standard equipment. All machines are manufactured to meet or exceed ANSI/ITSDF B56.6 - 2005 Standards or Recommended Practices, where applicable. Printed in Canada. Reorder Code: ALPHASS-NA-M-1-11

